

The

DI MARZIO EQUATION

for

STEREOGRAPHY

INDEX

<i>Derivation of the Di Marzio Equation</i>	2
• <i>Some notes and comments</i>	4
<i>Practical Forms of the Di Marzio Equation</i>	5
• <i>Determining the stereo base length using only the camera lens depth of field scale</i>	5
• <i>Determining the stereo base length graphically</i>	7
• <i>Some notes and comments</i>	11
<i>Special Cases</i>	
• <i>Hypostereography of Shallow Objects</i>	12
▪ <i>Macro stereography using image magnification</i>	15
• <i>Hyperstereography of Distant Subjects</i>	19
<i>Stereo Viewer Angular Magnification</i>	22
<i>Camera Lens/Viewer Lens Focal Length "Mismatch"</i>	26
<i>The Completely General Form of the Di Marzio Equation</i>	31
• <i>Di Marzio Equation for Freeviewing</i>	31
• <i>Di Marzio Equation for a Stereo Viewer</i>	33
<i>Calculating the f/Number</i>	35
<i>Generating a Depth of Field Scale</i>	40
<i>Designing a Depth of Field Scale for both Freeviewing and a Stereo Viewer</i>	43
<i>Summary of the Various Forms of the Di Marzio Equation</i>	53
<i>APPENDIX I: Extending the Range of Fixed Base Stereo Cameras</i>	55
<i>APPENDIX II: Comments Concerning the Diameter of the Circle of Confusion</i>	57
• <i>Freeviewing enlarged stereoscopic images</i>	57
• <i>Viewing using the stereoscopic viewer</i>	58
• <i>General 2D photography</i>	62
<i>APPENDIX III: Corrections for Arbitrary Freeviewing Distances</i>	64
• <i>Stereography with a short focal length digital camera</i>	70
<i>APPENDIX IV: "Stellar" Stereography</i>	71

Derivation of the Di Marzio Equation

John Bercovitz and others have used a simple geometrical approach to derive an expression for the stereo base B in terms of the object distance S_o , the focal length of the camera lens F_c and the near D_N and far D_F point distances required to be in acceptably sharp focus.

The result, known as the Bercovitz equation, is

$$B = d \left[\frac{D_F D_N}{D_F - D_N} \right] \left(\frac{1}{F_c} - \frac{1}{S_o} \right)$$

where d is the on-film deviation. For general stereography in which

$$S_o \gg F_c \quad \text{and} \quad D_F > 2D_N$$

the on-film deviation is usually taken to be $d = F_c / 30$.

Although the Bercovitz equation is a very powerful and general expression, it treats the near and far point distances as independent variables and is correspondingly more complicated than necessary.

If one realizes that the near and far points are not independent but related through f /number, then including geometrical optics allows a much simpler expression for stereo base to be found.

The last term in the Bercovitz equation is simply the image distance and can be written as

$$\frac{1}{S_o} - \frac{1}{F_c} = \frac{S_o - F_c}{S_o F_c}$$

The middle term can be written in a form suitable for simplification as

$$\left(\frac{D_F D_N}{D_F - D_N} \right) = \left(\frac{1}{D_N} - \frac{1}{D_F} \right)^{-1}$$

These near and far point distances can be expressed in terms of the object distance S_O , the focal length of the camera lens F_C and a quantity known as the hyperfocal distance D_H , namely

$$D_N = \frac{D_H S_O}{D_H + (S_O - F_C)} \quad D_F = \frac{D_H S_O}{D_H - (S_O - F_C)}$$

Thus the (reciprocal) middle term of the Bercovitz equation becomes

$$\frac{1}{D_N} - \frac{1}{D_F} = \left[\frac{D_H + (S_O - F_C)}{D_H S_O} \right] - \left[\frac{D_H - (S_O - F_C)}{D_H S_O} \right] = \frac{2(S_O - F_C)}{D_H S_O}$$

Hence the Bercovitz equation can be dramatically simplified, viz.

$$\begin{aligned} B &= d \left(\frac{1}{D_N} - \frac{1}{D_F} \right)^{-1} \left(\frac{1}{F_C} - \frac{1}{S_O} \right) \\ &= \frac{F_C}{30} \left[\frac{D_H S_O}{2(S_O - F_C)} \right] \left(\frac{S_O - F_C}{F_C S_O} \right) \end{aligned}$$

$$\therefore B = \frac{D_H}{60}$$

This is the fundamental form of the Di Marzio equation for the accurate evaluation of stereo base in general stereography.

Some notes and comments

This equation for stereo base is important for several reasons:

- It is a very simple, memorable and yet powerful and accurate expression for stereo base. Many stereographers mundanely use the rather simplistic (and sometimes unrealistic) "1 in 30" rule. However this "1 in 60" rule for hyperfocal distance is vastly more powerful and just as easy to remember.
- The hyperfocal distance D_H depends on the f/number N of the camera system, and so this simple quantity includes all of the depth of field information.
- Since there is only one value for the hyperfocal distance for each f/number, then there is correspondingly one and only one stereo base appropriate for each f/number.
- If the required depth of field can be captured at a particular f/number then the stereo base has a fixed value irrespective of the specific values for the near and far point distances of the subject(s). This is in complete contrast to the "1 in 30" rule which relates stereo base directly to near point distance.
- The hyperfocal distance (and f/number) is a computational tool by which the stereo base is determined. The stereographer is free to use whatever f/number they wish on their lens.

Practical Forms of the Di Marzio Equation

Determining the stereo base length using only the camera lens depth of field scale

The hyperfocal distance D_H is, by definition, the distance at which everything between half that distance and infinity will be rendered in acceptably sharp focus. It can also be described as the closest distance in acceptably sharp focus when the lens is focussed at infinity.

Consequently, in the simplest case, by setting a chosen f/number at infinity on the depth of field scale of a camera lens, the closest distance indicated as being in good focus will be half the hyperfocal distance corresponding to the f/number.

The following example illustrates how to find the hyperfocal distance for f/8. This depth of field scale is from an old Minolta lens.



With f/8 set to infinity, the nearest distance in good focus is 5m. Consequently since 5m corresponds to half the hyperfocal distance, then at f/8 the hyperfocal distance is 10m.

In addition, using the mathematical definition of hyperfocal distance in the next section, it can be shown that this lens depth of field scale was calibrated with a circle of confusion diameter of about 0.03mm.

It is therefore a simple matter to find the stereo base. By focussing on the near and far points of the required three dimensional scene, the depth of field scale reveals the smallest f/number capable of achieving this depth.

From that f/number, the hyperfocal distance can be found (again using the lens depth of field scale), and **one sixtieth of that hyperfocal distance is the required stereo base.**

This is true in general stereography whenever the far point distance is greater than or equal to twice the near point distance.

Determining the stereo base length graphically

A much more accurate value for the hyperfocal distance D_H can be evaluated from the expression

$$D_H = \frac{F_C^2}{CN}$$

where F_C is the camera lens focal length, N is the f/number and C is the diameter of the circle of confusion, which is a measure of the size of the image of a point that is still considered to be acceptably sharp.

The calculated values for D_H for a variety of common f/numbers N are presented in the table below for $F_C = 50\text{mm}$ and $C = 0.025\text{mm}$.

f/number N	D_H (m)	B (mm)
22	4.55	75.8
19.6	5.10	85.0
16	6.25	104.2
13.5	7.41	123.5
11	9.09	151.5
9.8	10.20	170.1
8	12.50	208.3
6.9	14.49	241.5
5.6	17.86	297.6

Alternatively, for a given lens focal length F_C and circle of confusion C , a graph of stereo base versus f/number N can be plotted which allows accurate determination of stereo base at a glance.

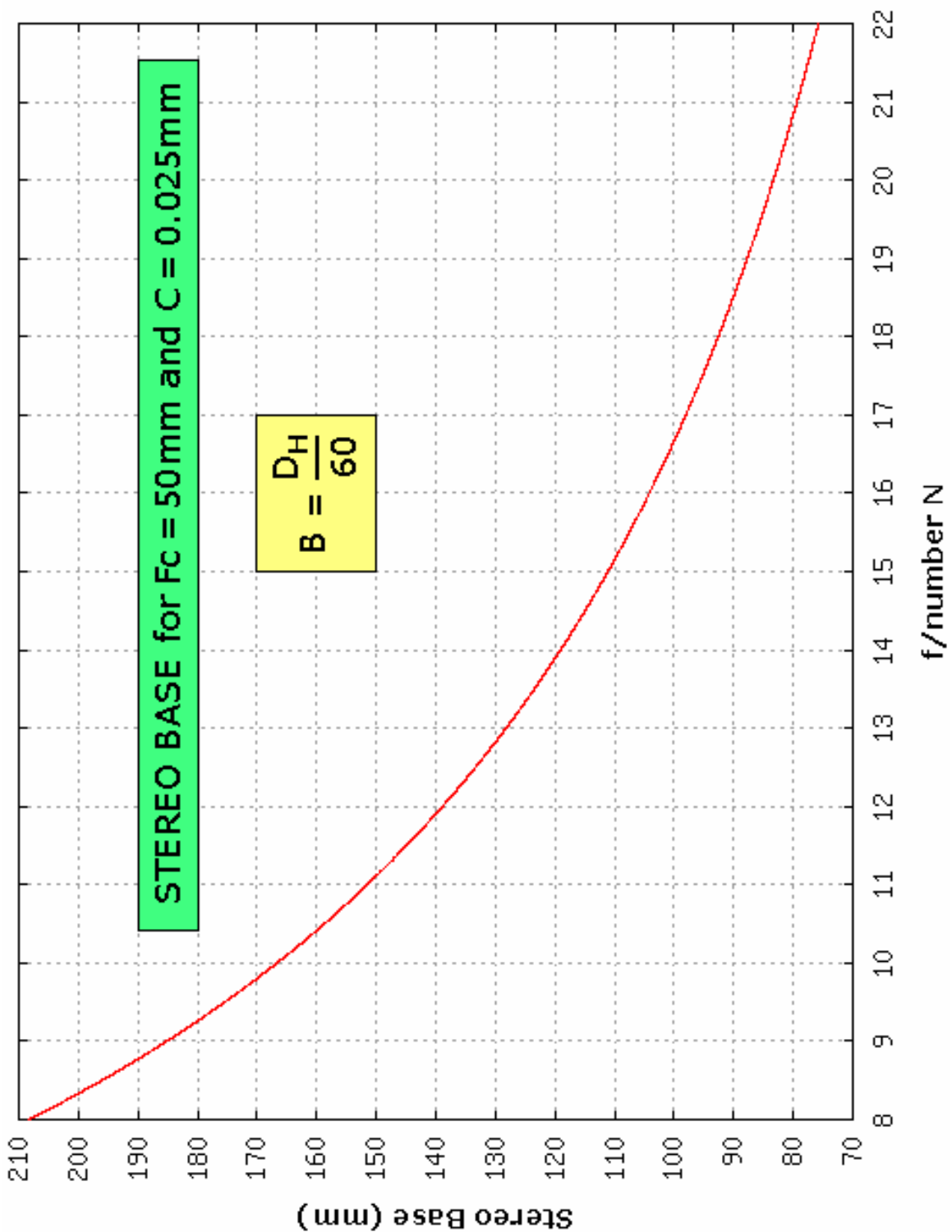

By substituting the definition of hyperfocal distance into the Di Marzio equation, it can be recast in terms of the f/number as

$$B = \frac{F_C^2}{60CN}$$

Since, for a particular camera, the focal length F_C and the diameter of the circle of confusion C are fixed, then the stereo base is inversely proportional to the f/number, that is

$$B = \frac{\text{constant}}{N}$$

In the previous case with $F_C = 50\text{mm}$ and $C = 0.025\text{mm}$, this gives

$$B = \frac{1667}{N}$$

where B has units of millimetres. It is then a simple matter to draw up a table of B and N or a plot of B versus N .

Given that the hyperfocal distances are based on a specific value for the circle of confusion diameter, **the f/number needs to be predicated on the same circle of confusion size**. It is possible to ensure that this condition is met in two ways.

1. If one plans to use the camera lens depth of field scale, then the hyperfocal distance D_H at some f/number N can be found. From the definition of D_H and the known values of F_C and N , the diameter of the circle of confusion C can also be found.

In the earlier example of the Minolta lens depth of field scale, the hyperfocal distance at f/8 was 10m. Therefore the diameter of the circle of confusion C is

$$10000 = \frac{50 \times 50}{C \times 8} \quad \text{and so} \quad C = 0.03\text{mm}$$

Since $C = 0.03\text{mm}$ and $F_C = 50\text{mm}$, then the general stereo base equation can be written as

$$B = \frac{50 \times 50}{60 \times 0.03 \times N} = \frac{1389}{N}$$

This simple equation will work for that Minolta lens and can be used to draw a graph of B versus N for that camera.

2. Depending on the lens being used, the depth of field scale may be difficult to read reasonably accurately. In this event, it is possible to generate a customized depth of field scale. The main advantage here is that such a scale can be made much larger than any on a camera lens and allows an easy evaluation of f/number. This will be discussed in detail in the section entitled "Generating a Depth of Field Scale".

Some notes and comments

- ▶ The f/number N in the Di Marzio equation is the **smallest** f/number capable of covering the desired depth of field of the scene. It is this smallest value that is used to ascertain the stereo base.
- ▶ Since the base B depends on the (smallest) f/number N , then any combination of near and far points producing a depth of field compatible with N will require the same stereo base. There is no need to redetermine the stereo base in these cases.
- ▶ When freeviewing, the optimum viewing distance is ES_i where E is the image enlargement factor and S_i is the image distance (the distance of the lens from the film/chip plane). In general stereography, $S_i \approx F_C$ and so this optimum freeviewing distance is usually EF_C .
- ▶ One of the most powerful aspects of the Di Marzio equation is that it can automatically cater for differences in the focal lengths of the camera and stereo viewer. A correction factor for this focal length mismatch can be encapsulated within the f/number itself. This will be discussed in detail in the section entitled "Camera Lens/Viewer Lens Focal Length Mismatch".
- ▶ Although the characteristics of the depth of field scale depends on the diameter of the circle of confusion C , the stereo base does not. Specifically, the Di Marzio equation for stereo base contains a factor CN . However N is inversely proportional to C . So if you double the value of C , the value for N halves. That is, irrespective of the value for C , the factor CN remains the same.

SPECIAL CASES

Hypostereography of Shallow Objects

If the Bercovitz equation is used to calculate stereo base for situations in which $D_F < 2D_N$, the image depth produced is too great.

Michael K. Davis and others have suggested that when $D_F < 2D_N$, one should simply determine the near point distance D_N and set the far point at $D_F = 2D_N$. Since D_F is actually less than $2D_N$ this yields a smaller value for the stereo base than that of the Bercovitz equation thereby properly allowing for diminishing depth of the subject.

This is an excellent modification as it permits the stereo base to be a smoothly decreasing percentage of the Bercovitz base. An example of this variation is displayed below for a near point distance of 500mm.

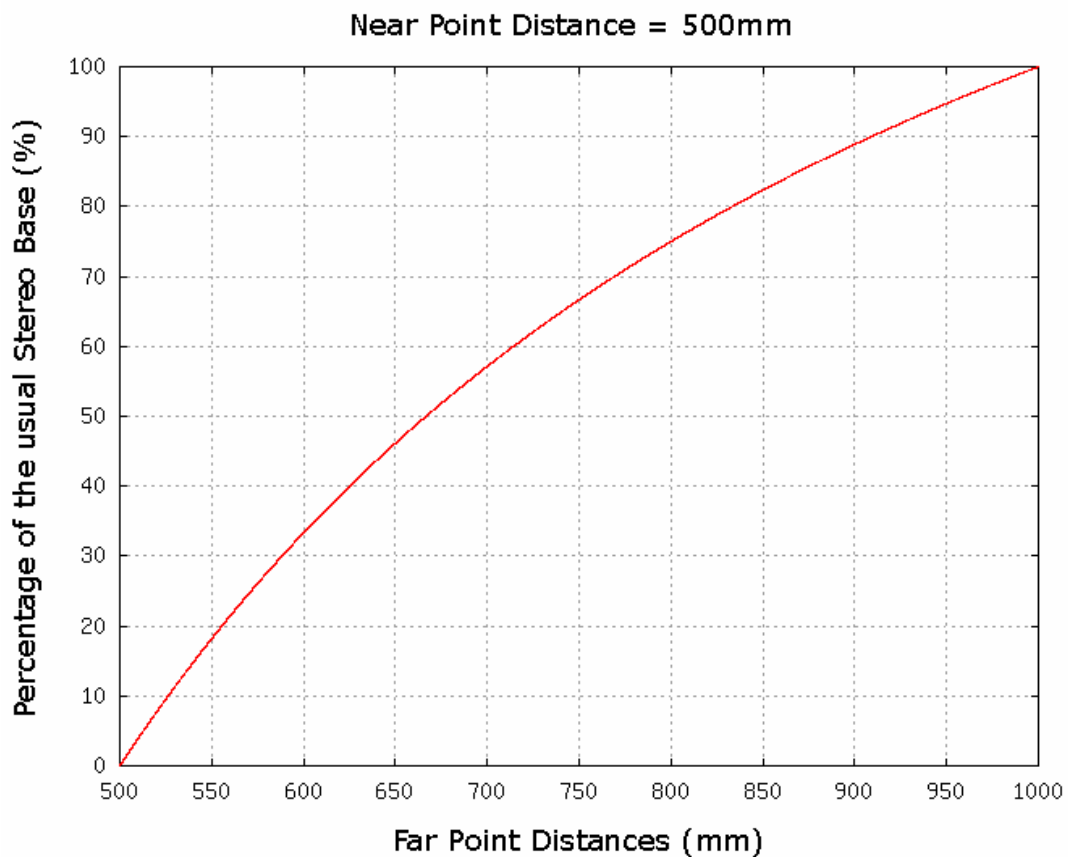

Not only does this deliberate tapering of the stereo base avoid exaggerated depth and allow a proper depth rendition in shallow subjects, but it also permits a trivial calculation for the stereo base.

The problem with the Bercovitz equation for shallow objects arises from the denominator in his equation. There is a $D_F - D_N$ term which makes the base too large for shallow objects. As you endeavour to photograph shallower and shallower objects, this term in the denominator becomes smaller and smaller, thereby making the stereo base unrealistically larger and larger.

With the Bercovitz equation, as the denominator $D_F - D_N$ approaches zero, the base approaches infinity — not a reasonable scenario. So the beauty of the Davis modification is twofold. It allows a smooth transition from deep to shallow subjects and it completely avoids unrealistically large stereo bases for very shallow subjects.

Realistic stereo bases are achieved using the Davis modification

$$D_F = 2D_N$$
$$S_o \equiv \frac{2D_N D_F}{D_N + D_F} = \frac{4D_N}{3}$$

Further, the on-film deviation is not set to one thirtieth of the lens focal length but one thirtieth of the image distance (lens to film/chip plane distance) so as to ensure a constant parallax angle of 1.9° is maintained irrespective of the type of stereography undertaken. This is particularly important in macro stereography where $S_i > F_C$. Hence

$$d = \frac{S_i}{30}$$

Substituting these expressions into the Bercovitz equation yields an amazingly simple expression for stereo base which depends only on the near point distance, viz.

$$B = \frac{D_N}{15}$$

Note that this equation is a trivially simple and yet very powerful expression for stereo base which only requires a knowledge of the near point distance. In addition, it suggests that if one were to use the popular "1 in 30" rule for such nearby, shallow objects, the resulting stereo base would be in error by a factor of two.

Macro stereography using image magnification

If a macro lens is calibrated for distance then the "1 in 15" rule is easy to apply. However if the lens is calibrated in terms of magnification (or the stereographer prefers using magnification rather than near distance), then it is possible to write the "1 in 15" rule for near distance in terms on macro lens magnification.

The depth of field Δ from the object distance S_o to the near point D_N is

$$\Delta = S_o - D_N$$

Since the near point distance is related to the hyperfocal distance D_H via the relation

$$D_N = \frac{D_H S_o}{D_H + (S_o - F_c)}$$

then this depth of field can be written as

$$\begin{aligned} \Delta &= S_o - \frac{D_H S_o}{D_H + (S_o - F_c)} \\ &= S_o \left(1 - \frac{1}{1 + \left(\frac{S_o - F_c}{D_H} \right)} \right) \end{aligned}$$

Using the thin lens equation it can shown that

$$S_o - F_c = \frac{F_c}{M}$$

where M is the magnification of the lens when focussed at the object distance. Substituting this into the previous expression and simplifying yields the result

$$\Delta = \frac{S_o F_c}{MD_H + F_c}$$

Using the definition of hyperfocal distance and the fact that $MD_H \gg F_c$ and so $MD_H + F_c \approx MD_H$ yields,

$$\Delta = \frac{S_o CN}{MF_c}$$

Similarly if the depth of field behind the object distance were to be found from $\Delta = D_F - S_o$, then using the definition of far point, namely

$$D_F = \frac{D_H S_o}{D_H - (S_o - F_c)}$$

would give a similar expression,

$$\Delta = \frac{S_o F_c}{MD_H - F_c}$$

with the only difference being the minus sign in the denominator. Again, $MD_H \gg F_c$ and $MD_H - F_c \approx MD_H$ and the depth of field is

$$\Delta = \frac{S_o CN}{MF_c}$$

That is, the depth of field in front of the object is the same as the depth of field behind it and the total depth of field is simply 2Δ . In addition, **the depth of field does not depend on the lens focal length** and, since $S_o/F_c = (M+1)/M$, can also be written as

$$2\Delta = \frac{2CN(M+1)}{M^2}$$

Hence the near point distance (and thus the stereo base as well) can be written in terms of the lens magnification.

$$D_N = S_o - \Delta = S_o - \frac{S_o CN}{MF_C}$$

$$= \frac{S_o}{F_C} \left(\frac{MF_C - CN}{M} \right)$$

From the thin lens equation, as earlier, $S_o/F_C = (M+1)/M$ and so

$$D_N = \left(\frac{M+1}{M^2} \right) (MF_C - CN)$$

However $MF_C \gg CN$ and so $MF_C - CN \approx MF_C$. Hence the near distance can be written accurately as

$$D_N = F_C \left(\frac{M+1}{M} \right)$$

Thus the stereo base can be written in terms of magnification M as

$$B = \frac{F_C}{15} \left(1 + \frac{1}{M} \right)$$

Note that in the special case of lifesize ($M = 1$) macro stereography, the stereo base is simply $B = F_C/7.5$.

A graph of stereo base versus magnification for a 50mm focal length lens is displayed below, providing stereo base information at a glance.

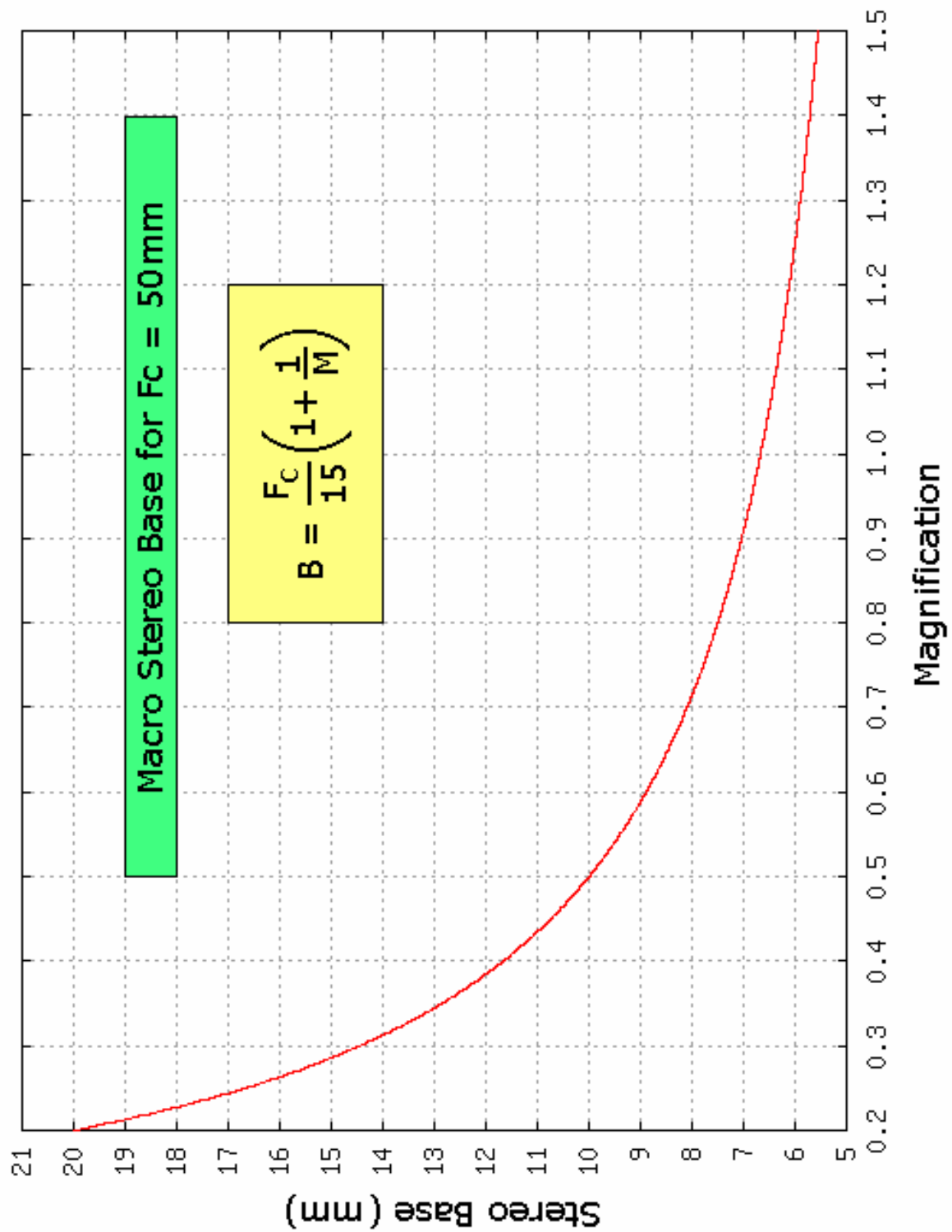

SPECIAL CASES

Hyperstereography of Distant Subjects

Situations in which $D_F \geq 2D_N$ do not present a problem unless D_N itself is large. If these cases it becomes difficult if not impossible to use an ordinary depth of field scale to determine the appropriate f/number N for finding the stereo base. There is a simple way around this problem.

If D_N is large (several metres or more) and $D_F = mD_N$ where $m \geq 2$, then the Bercovitz equation can be simplified yet again. Since the object distance S_O is large here, then

$$\frac{1}{F_C} - \frac{1}{S_O} \approx \frac{1}{F_C}$$

is an excellent approximation in such circumstances. Consequently

$$B = \left(\frac{F_C}{30}\right) \left[\frac{D_N(mD_N)}{mD_N - D_N}\right] \left(\frac{1}{F_C}\right)$$

$$\therefore B = \left(\frac{m}{m-1}\right) \frac{D_N}{30}$$

which is a simple and powerful expression for stereo base relevant to hyperstereoscopy (as well as general stereography for that matter). This equation will be referred to as the “modified 1 in 30” rule.

Note that when m is large, that is, when the far point distance is much greater than the near point, such as in landscape stereography, then

$$\left(\frac{m}{m-1}\right) \rightarrow 1 \quad \text{and} \quad B \rightarrow \frac{D_N}{30}$$

which is the familiar "1 in 30" rule. Clearly the "1 in 30" rule is valid only when the far point distance is very large or, from a photographic point of view, infinity.

This is a fairly severe limitation on stereography and is a reflection of the overall inadequacy of the "1 in 30" rule. In fact, if $m = 5$, the stereo base using the "1 in 30" rule is already in error by 20%. Clearly such a rule is especially inadequate for shallow objects which involve stereo bases more realistically described by a "1 in 15" rule.

In the "modified 1 in 30" rule, the approximation that the lens to image distance is the same as its focal length is an excellent one for near distances of several metres or more. In fact an error of $n\%$ occurs whenever the lens focal length F_C is

$$F_C = \left[\frac{2nm}{n+100} \right] \frac{D_N}{(m+1)}$$

A graph of focal length versus near distance is displayed below for $m = 5, 10$ and 20 and which results in a 5% error in stereo base. Clearly very large focal lengths are required in order for the "modified 1 in 30" rule to produce even a small error of 5% in the stereo base.

Lastly, determining near and far point distances in hyperstereography can be achieved quite accurately with the aid of a good map or even a street directory. Some very careful and deliberate stereographers even resort to using laser rangefinders.

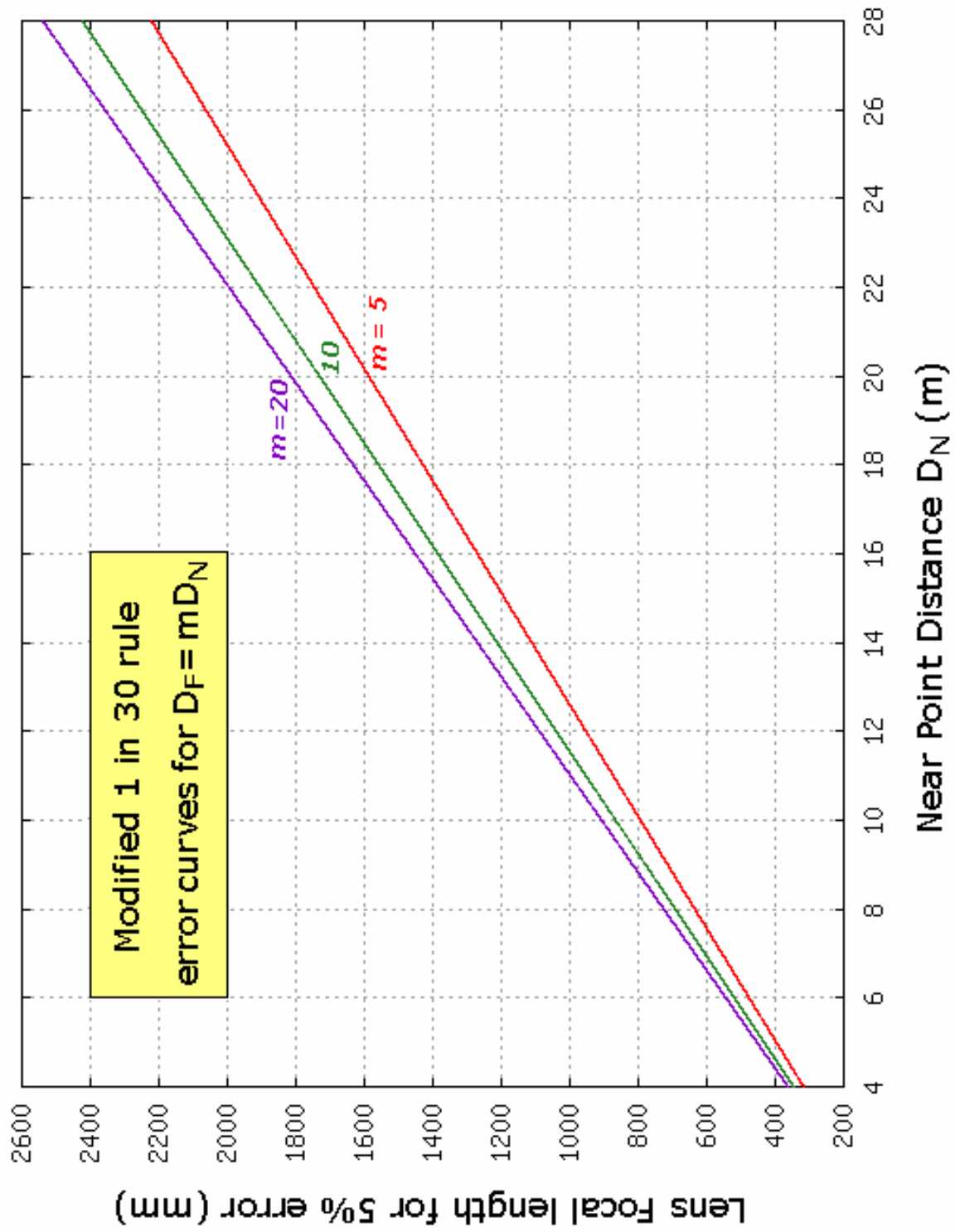

Stereo Viewer Angular Magnification

The angular magnification of any optical system is defined as the angle subtended by the image of an object as seen through the optical system compared with the angle subtended by the object at a fixed (standard) distance of 10" (254 mm). This is illustrated (but not to scale) in the following two diagrams.

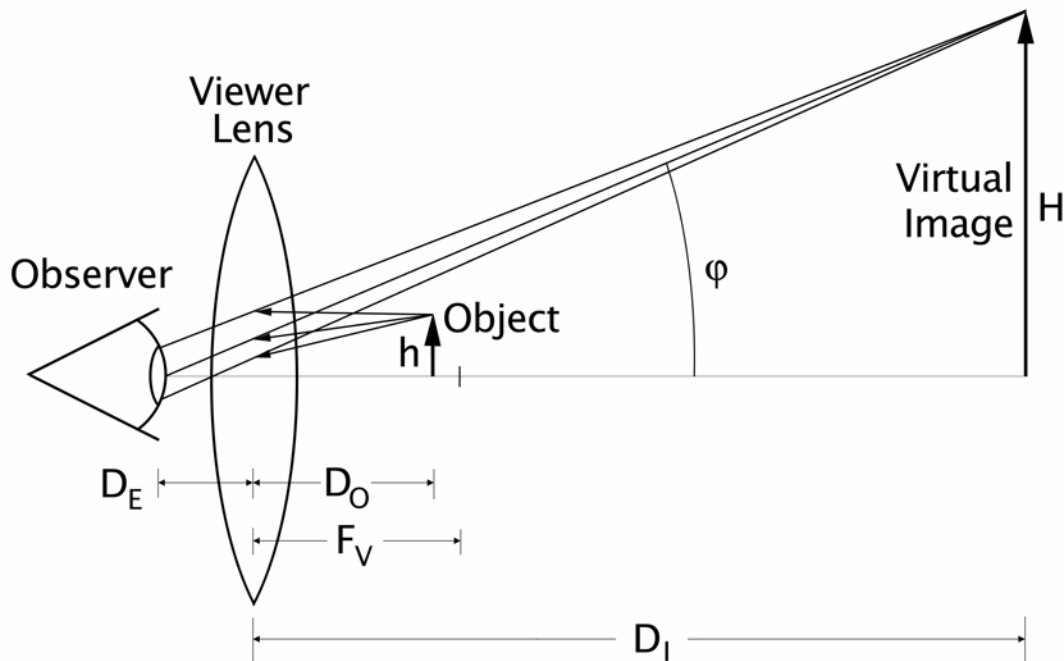

D_O = distance of the object from the lens

D_E = distance of the observer's eye from the lens

D_I = distance of the image from the lens

F_V = focal length of the viewer lens

h = height of object under consideration

ϕ = angle subtended by the virtual image of amplified height H

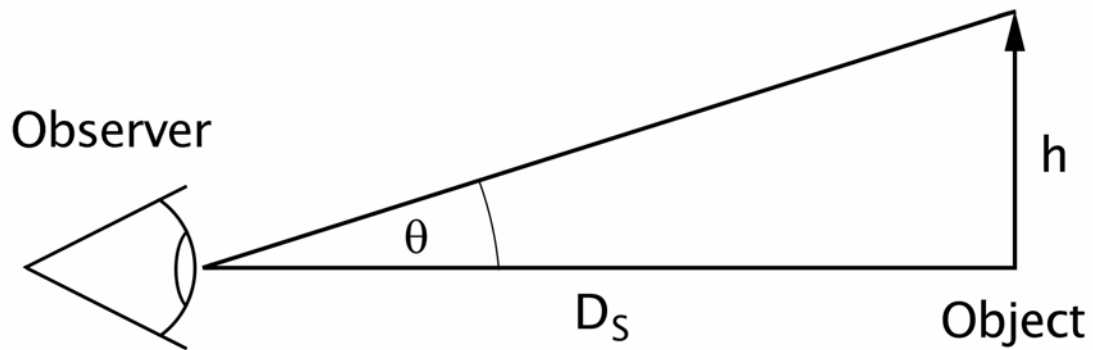

D_S = standard viewing distance of 254mm

h = height of object under consideration

θ = angle subtended by the object at this distance

Using the notation in the previous two diagrams, an expression for the angular magnification M_V of the viewer can be written as

$$M_V = \frac{\phi}{\theta}$$

Since $\tan \theta = h/D_S \simeq \theta^c$ and $\tan \phi = H/(D_I + D_E) \simeq \phi^c$, then

$$M_V = \left(\frac{H}{h} \right) \left[\frac{D_S}{D_I + D_E} \right]$$

Using straightforward geometrical optics, the appropriate sign convention and the thin lens equation, namely

$$\frac{1}{D_I} + \frac{1}{D_O} = \frac{1}{F_V}$$

enables the expression for the angular magnification to be recast as

$$M_V = \left[1 + \frac{D_I}{F_V} \right] \left(\frac{D_S}{D_I + D_E} \right) = D_S \left(\frac{1}{D_{IE}} + \frac{D_I}{F_V D_{IE}} \right)$$

where D_{IE} is the distance of the image from the eye of the observer.

Given that the eye is always close to the viewer lens, then the distance between the image and the lens is essentially the same as the distance between the image and the eye, i.e. $D_{IE} \simeq D_I$. Hence, to an excellent approximation, the final expression for the angular magnification of the viewer can be written as

$$M_V = D_S \left(\frac{1}{F_V} + \frac{1}{D_I} \right)$$

This equation highlights the important fact that **the angular magnification of the stereo viewer depends not only on the focal length of the viewer lens, but also on the position one chooses to place the image.**

The image position can be varied because the distance between the lens and the object (slide film) is adjustable in some cases. If the film chips are placed at the focal point of the viewer lenses, then the virtual image is formed at infinity and the angular magnification is then

$$M_V(D_I = \infty) = \frac{254}{F_V}$$

This corresponds to the angular magnification of the most comfortable viewing since focussing at infinity involves minimal eye strain.

On the other hand, if the viewer lenses are adjusted so that an image is formed at the observer's close focus distance D_c then

$$M_v(D_i = D_c) = 254 \left(\frac{1}{F_v} + \frac{1}{D_c} \right)$$

If the close focus distance is 10" (254mm) then the angular magnification is given by

$$M_v(D_c = D_s) = \frac{254}{F_v} + 1$$

Accordingly the vast majority of the population can experience viewer angular magnifications between $254/F_v$ and $254/F_v + 1$. Youngsters who can focus down to 5" (127mm) benefit the most, experiencing viewer angular magnifications ranging from $254/F_v$ to $254/F_v + 2$.

However, this angular magnification benefit may be at the expense of realistic stereo depth. In the next section, it will be shown that the stereo base required for stereographic imaging depends on where the observer decides to place the viewer image.

As a result of this, different observers who place the viewer image at different distances from the viewer lens, will observe different stereoscopic depth. In other words, **varying the angular magnification will vary the amount of perceived image depth** in a similar manner as varying viewing distance when freeviewing.

Camera Lens/Viewer Lens Focal Length “Mismatch”

In order to generate consistent depth when viewing stereo pairs, presumably it is important that the viewer focal length “match” the camera focal length. In order to investigate the effects of focal length mismatch, it is necessary to determine the scaling required for the stereo base that will provide consistent stereo depth.

For some time the mismatch between camera and viewer focal lengths has been corrected by scaling the stereo base by the factor F_V/F_C , where F_V and F_C are the focal lengths of the viewer and camera lenses respectively. However this correction is only valid when the stereo viewer image is placed at infinity (film chips located at the focal points of the viewer lenses), but it fails for final images closer than this.

What is required is an expression for the ratio of the angular magnification of camera to viewer, as this will correct for focal length mismatches and for any final image position.

As noted earlier the angular magnification of the viewer is

$$M_V = D_s \left(\frac{1}{F_V} + \frac{1}{D_I} \right) = 254 \left(\frac{D_I + F_V}{F_V D_I} \right)$$

Similarly the angular magnification of a camera can be established by comparing the angle subtended by a real image formed by the camera lens of an object (on the film) to that subtended by the same object placed at the standard distance of 254mm.

This then yields a camera angular magnification M_C given by

$$M_C = \left(\frac{h}{S_I} \right) / \left(\frac{h}{254} \right) = \frac{254}{S_I}$$

where the approximation $\tan \theta \simeq \theta^c$ was used justifiably as the angles are always small in this case.

Consequently to properly account for camera lens/viewer lens focal length "mismatch", the stereo base must be scaled by M_C/M_V , namely

$$\frac{M_C}{M_V} = \left(\frac{254}{S_I} \right) \left[\frac{F_V D_I}{254(D_I + F_V)} \right] = \frac{F_V}{S_I} \left(\frac{D_I}{D_I + F_V} \right)$$

Applying the thin lens equation for the image distance yields

$$\frac{1}{S_I} = \frac{1}{F_C} - \frac{1}{S_O} = \frac{S_O - F_C}{F_C S_O}$$

and substituting this back into the expression for M_C/M_V yields the final result for the scaling for camera/viewer focal length mismatch as

$$\frac{M_C}{M_V} = \frac{F_V}{F_C} \left(\frac{D_I}{F_V + D_I} \right) \left(\frac{S_O - F_C}{S_O} \right)$$

There are some very interesting points arising from this general equation for focal length mismatch:

- Clearly $D_I/(F_V + D_I)$ is always positive and less than one.
- Consequently **M_C/M_V is always less than F_V/F_C** and so **the factor F_V/F_C always overestimates the value for the stereo base whenever $D_I \neq \infty$.**
- **The ONLY time $F_V/F_C = M_C/M_V$ is when the image distance $D_I = \infty$** (with a concomitant loss of angular magnification). It will be demonstrated later that this is true irrespective of the value of the object distance S_O .
- The scaling M_C/M_V works correctly in all circumstances because it specifically takes into consideration the exact distance of the image on the film from the camera lens. Accordingly the expression for M_C/M_V also caters for stereo photomacrography.

A table demonstrating the marked differences in the values of the scalings for focal length mismatch are presented over page.

It compares the values predicted using the corrections F_V/F_C and M_C/M_V with a fixed object distance $S_O = 3000\text{mm}$.

D_I	F_C	F_V	F_V/F_C	M_C/M_V	$(M_C/M_V)/(F_V/F_C)$
250	35	44	1.26	1.06	0.84
250	35	78	2.23	1.68	0.75
250	50	44	0.88	0.74	0.84
250	50	62	1.24	0.98	0.79
250	50	78	1.56	1.17	0.75
250	75	44	0.59	0.49	0.83
250	75	78	1.04	0.77	0.74
250	180	78	0.43	0.31	0.72
250	300	78	0.26	0.18	0.69
Infinity	35	44	1.257	1.242	0.99
Infinity	50	62	1.240	1.219	0.98
Infinity	75	78	1.040	1.014	0.975

This table highlights some further important facts:

- With all else being constant, the disparity between M_C/M_V and F_V/F_C increases with increasing F_C .
- With all else being constant, the disparity between M_C/M_V and F_V/F_C increases with increasing F_V .
- **If $F_V = F_C$, then the focal length “mismatch” correction (even though there is no longer any focal length mismatch) is generally NOT equal to one.** The mismatch scaling factor M_C/M_V in this case depends on both F_V and D_I .
 - **If $D_I = \infty$, then $M_C/M_V = F_V/F_C$ irrespective of the value of F_V . This is the ONLY time when stereo base is unaltered when $F_V = F_C$.**
 - If $D_I \neq \infty$, then $M_C/M_V < F_V/F_C$ irrespective of F_V .
 - For a fixed, non-infinite D_I , $M_C/M_V \rightarrow F_V/F_C$ as $F_V \rightarrow 0$.
 - Conversely, for a fixed F_V , $M_C/M_V \rightarrow F_V/F_C$ as $D_I \rightarrow \infty$.
- For stereographers who, in the past, have used the inappropriate focal length mismatch scaling factor of F_V/F_C , their only recourse to improved image depth is to sacrifice some angular magnification by using a large viewer image distance, i.e. to place the film chips close to the focal point of the viewer lenses.
- There is the critical realization that **the amount of scaling of the stereo base needed to account for focal length mismatch depends on where the observer intends to place the image in their viewer.**

The Completely General Form of the Di Marzio Equation

Di Marzio Equation for Freeviewing

Earlier it was noted that the Di Marzio equation can be written as

$$B = \frac{D_H}{60} = \frac{F_C^2}{60CN}$$

However there are two ways in which this can be evaluated.

1. Using the camera lens circle of confusion

As noted earlier, the lens depth of field scale can be used to determine hyperfocal distance D_H and from that, the diameter of the circle of confusion C . Knowing the value of C then allows the stereographer to write the Di Marzio equation in a form specific to their lens. In the example involving the Minolta lens this was

$$B = \frac{1389}{N}$$

The lens depth of field scale can then be used to find the smallest N capable of handling the required depth of field. The base can then either be found using a calculator or by looking up a predetermined table of B and N values. This is by far the simplest approach.

This method works very well indeed in general stereography, but some cameras can have depth of field scales that are a little on the small side. In this case it is possible to generate your own (much larger) depth of field scale.

2. Producing your own depth of field scale

This is a somewhat more involved technique but it does allow for more precise stereography. It will be shown later on in the next section that the f/number N can be written in terms of the near D_N and far D_F distances, the lens focal length F_C and the diameter of the circle of confusion C . In fact $N \propto 1/C$ and so the factor CN results in a stereo base that is independent of C , as it should be.

Furthermore, if one selects a circle of confusion diameter of

$$C = \frac{F_C}{2000}$$

then the Di Marzio equation for freeviewing can be written as

$$B = \frac{100 F_C}{3 N}$$

on the understanding that N is based on the same circle of confusion.

Lastly the optimum freeviewing distance is $D_{FV} = ES_i$, where E is the enlargement factor of the film and S_i is the lens to film distance. This optimum freeviewing distance is generally a comfortable distance. In the unlikely event that this is not the case, then the stereo base can be adjusted using the arbitrary freeviewing distance correction factor discussed in Appendix III.

Di Marzio Equation for a Stereo Viewer

When using a stereo viewer, the diameter of the circle of confusion depends on the final image position and is described by (the proof can be found in Appendix II entitled "Comments Concerning the Diameter of the Circle of Confusion")

$$C = \frac{D_I F_V}{2000 (F_V + D_I)}$$

In addition the correction that needs to be applied to the stereo base for camera lens/viewer lens focal length mismatch is

$$\frac{M_C}{M_V} = \frac{F_V}{F_C} \left(\frac{D_I}{F_V + D_I} \right) \left(\frac{S_O - F_C}{S_O} \right)$$

In the macrostereography section it was suggested that the on-film deviation should be set to $S_i/30$ to ensure a parallax angle of 1.9° .

If this condition is applied to the Di Marzio equation then an extra factor of $S_O/(S_O - F_C)$ appears. In general stereography this is of little consequence since this factor is very close to one. However it does simplify matters when using a stereo viewer.

The final stereo base expression involves this extra factor, the general expression for circle of confusion diameter given above as well as the scaling for camera lens/viewer lens focal length mismatch.

The stereo base can thus be written as

$$B = \frac{F_C^2}{60CN} \left(\frac{S_o}{S_o - F_C} \right) \frac{M_C}{M_V}$$

$$= \frac{F_C^2}{60N} \left[\frac{2000(F_V + D_I)}{D_I F_V} \right] \left(\frac{S_o}{S_o - F_C} \right) \left(\frac{F_V}{F_C} \right) \left(\frac{D_I}{F_V + D_I} \right) \left(\frac{S_o - F_C}{S_o} \right)$$

Therefore **the completely general form of the Di Marzio equation when using a stereo viewer** is

$$B = \frac{100 F_C}{3 N}$$

Note that although this equation is identical to that for freeviewing, the f/number in the stereo viewer case is based on a different circle of confusion diameter.

Although it may appear that the focal length of the viewer F_V and the viewer image distance D_I are absent in the above expression for stereo base, they are in fact contained within the f/number N through the expression for the diameter of the circle of confusion. This is discussed in the next section.

Calculating the f/Number

The smallest value for N needed for substitution into the Di Marzio equation can be determined by using the definitions of near and far points, namely

$$D_N = \frac{D_H S_0}{D_H + (S_0 - F_C)}$$

$$D_F = \frac{D_H S_0}{D_H - (S_0 - F_C)}$$

$$\therefore \frac{D_F}{D_N} = \frac{[D_H + (S_0 - F_C)]}{[D_H - (S_0 - F_C)]} = 1 + \frac{2(S_0 - F_C)}{D_H - (S_0 - F_C)}$$

$$\therefore \frac{D_N}{D_F - D_N} = \frac{D_H - (S_0 - F_C)}{2(S_0 - F_C)}$$

$$\therefore D_H \equiv \frac{F_C^2}{CN} = (S_0 - F_C) \left[\frac{D_F + D_N}{D_F - D_N} \right]$$

$$\therefore N = \frac{F_C^2}{C(S_0 - F_C)} \left[\frac{D_F - D_N}{D_F + D_N} \right]$$

Given that the object distance S_0 can be written in terms of the near and far point distances D_N and D_F as

$$S_0 = \frac{2D_N D_F}{D_F + D_N}$$

Then the focal ratio can be expressed in its final form as

$$N = \frac{(D_F - D_N)F_C^2}{C [2D_N D_F - F_C (D_N + D_F)]}$$

where, for a stereo viewer,

$$C = \frac{D_I F_V}{2000 (F_V + D_I)}$$

Some examples of the effects of viewer final image distance D_I and viewer lens focal length F_V on f/number N are tabulated and plotted below for a 50mm focal length camera lens.

The variation of f/number N as a function of viewer image distance for various near and far point distances.

$F_V = 62\text{mm}$	$(D_N, D_F) = (2, 5)\text{m}$	$(D_N, D_F) = (3, 10)\text{m}$	$(D_N, D_F) = (5, 100)\text{m}$
D_I	N	N	N
200	18.0	13.9	11.3
250	17.2	13.3	10.7
300	16.6	12.8	10.4
350	16.2	12.5	10.1
400	15.9	12.3	9.9
450	15.7	12.1	9.8
500	15.5	12.0	9.7

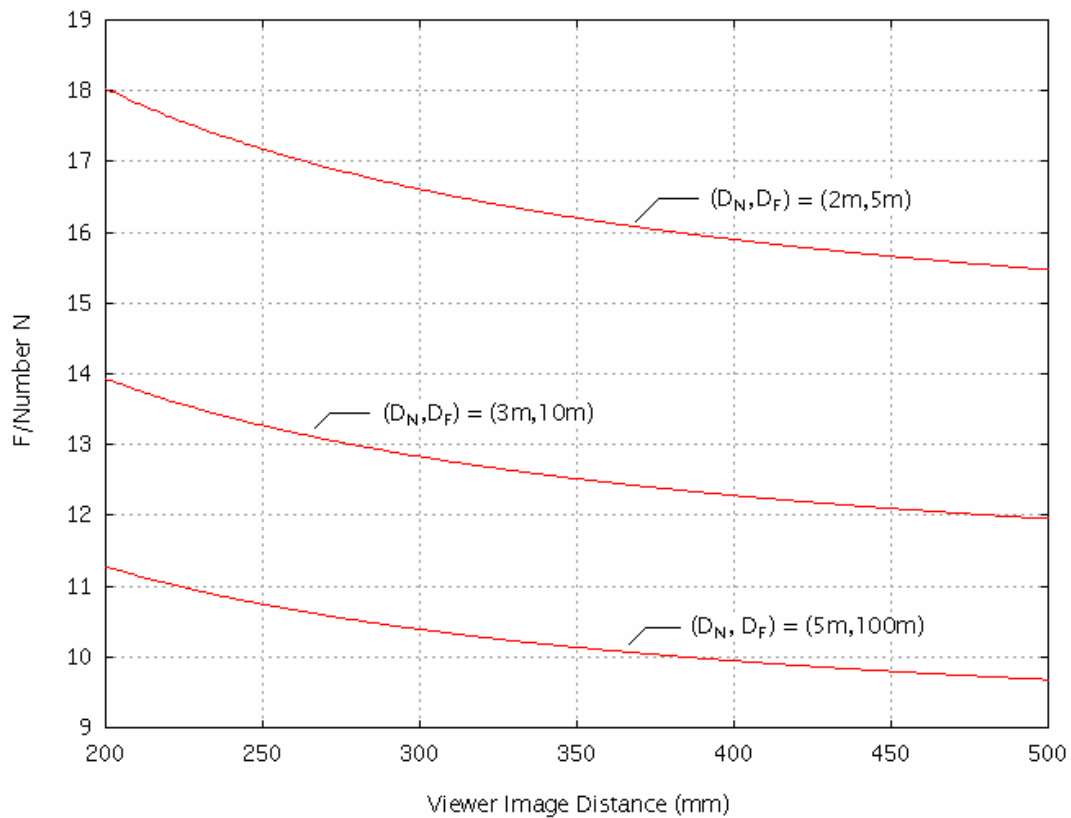

The variation of f/number N as a function of viewer focal length for various near and far point distances.

$D_I =$ 254mm	$(D_N, D_F) =$ (2,5)m	$(D_N, D_F) = (3,10)$ m	$(D_N, D_F) = (5,100)$ m
F_V (mm)	N	N	N
40	24.7	19.1	15.4
45	22.3	17.2	14.0
50	20.4	15.8	12.8
55	18.9	14.6	11.8
60	17.6	13.6	11.0
65	16.5	12.7	10.3
70	15.6	12.0	9.7

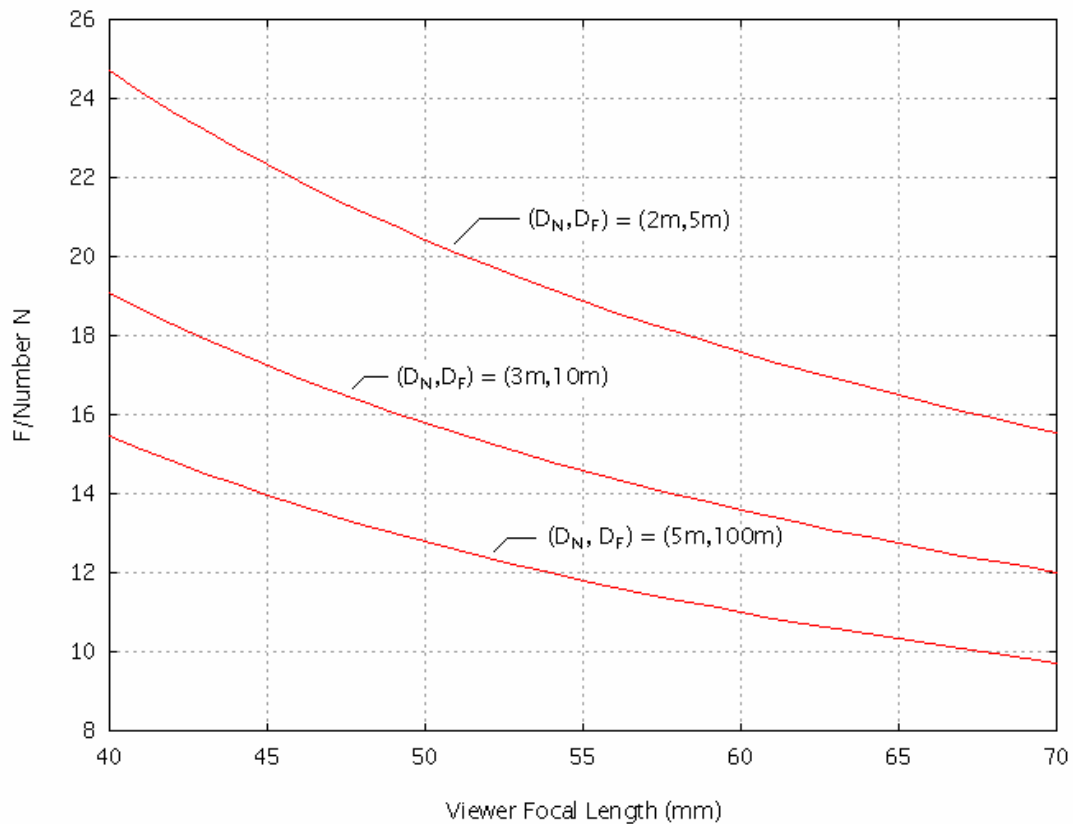

The previous graphs display the variation of f/number with viewer image distance and viewer focal length for a fixed camera focal length. The f/number N required to render acceptably sharp images between near and far point distances

- **decreases with increasing viewer image distance**
- **decreases with increasing viewer focal length**

By substituting the general expression for the required f/number N into the Di Marzio equation, one notes that **the stereo base**

- **increases with increasing viewer image distance**
- **increases with increasing viewer focal length**

Once a final viewer image distance is decided upon, the general expression for N can be used to generate a depth of field scale specific to the individual needs of the stereographer. Note that this only needs to be done once.

Generating a Depth of Field Scale

By choosing the appropriate value for the diameter of the circle of confusion, either for freeviewing or for use with a stereo viewer, a calculation can be performed over a large range of near and far distances using a particular value for the f/number N.

The previous expression for f/number N can be rearranged to give the far distance D_F in terms of the near distance D_N , the circle of confusion diameter C and the camera lens focal length F_C , namely

$$D_F = \frac{D_N \left(1 - \left[\frac{CN}{F_C} \right] \right)}{\left\{ 1 - \left[\frac{CN}{F_C^2} \right] (2D_N - F_C) \right\}}$$

By selecting a value for N and C, one can loop over a large range of D_N values using very small increments and calculate the corresponding D_F for each D_N . A computer program is capable of doing this very quickly and accurately with all the values being saved onto hard disk.

The results can then be examined to select those values of D_N and D_F corresponding to common distances. Moreover for each (D_N, D_F) pair, the object distance S_O can also be evaluated at the same time and saved to disk thereby increasing the chances of finding even more useable distances to include on the depth of field scale.

This entire procedure is repeated for every desired f/number. Finally these distances and f/numbers can be plotted to produce a large, accurate depth of field scale.

An example of a depth of field scale generated in this manner is presented below for $F_c = 50\text{mm}$ and $C = 0.025\text{mm}$. Note that this depth of field scale is also suitable for use with a stereo viewer with lenses of 62mm focal length when the final image is placed about 254mm (10") behind the lenses.

Dual purpose depth of field scales will be discussed in the next section.

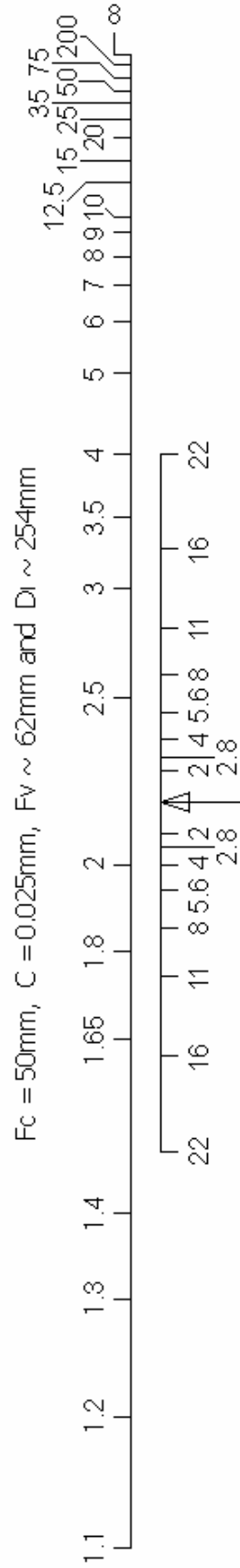

$F_c = 50\text{mm}$, $C = 0.025\text{mm}$, $F_v \sim 62\text{mm}$ and $D_i \sim 254\text{mm}$

Designing a Depth of Field Scale for both Freeviewing and a Stereo Viewer

As noted earlier, one can either stereo view or freeview a stereo pair. However, the value of N for each method of viewing is almost always different because the diameter of the circle of confusion is different in each case.

In order to determine the level of disparity between the required f/numbers N in each case (and thus the disparity in the resultant stereo base as well), it is necessary to look at the ratio of N for a stereo viewer N_V to that for freeviewing N_F . This ratio can be written

$$\frac{N_V}{N_F} = F_C \left(\frac{F_V + D_I}{F_V D_I} \right)$$

A graph of this ratio for $F_C = 50\text{mm}$ and $F_V = 62\text{mm}$ is displayed on the next page as a function of viewer image distance D_I . As can be seen, at the standard image distance of 254mm, the ratio of the f/numbers is almost exactly equal to one. In other words, for this equipment and image distance of about 254mm, the previous depth of field scale can be used successfully for both freeviewing and when using a stereo viewer.

Conversely, if $F_C = 50\text{mm}$ and $F_V = 44\text{mm}$ (rather than 62mm), then the ratio of the f/numbers associated with freeviewing and when using a stereo viewer are markedly different and never equal to one (see graph below).

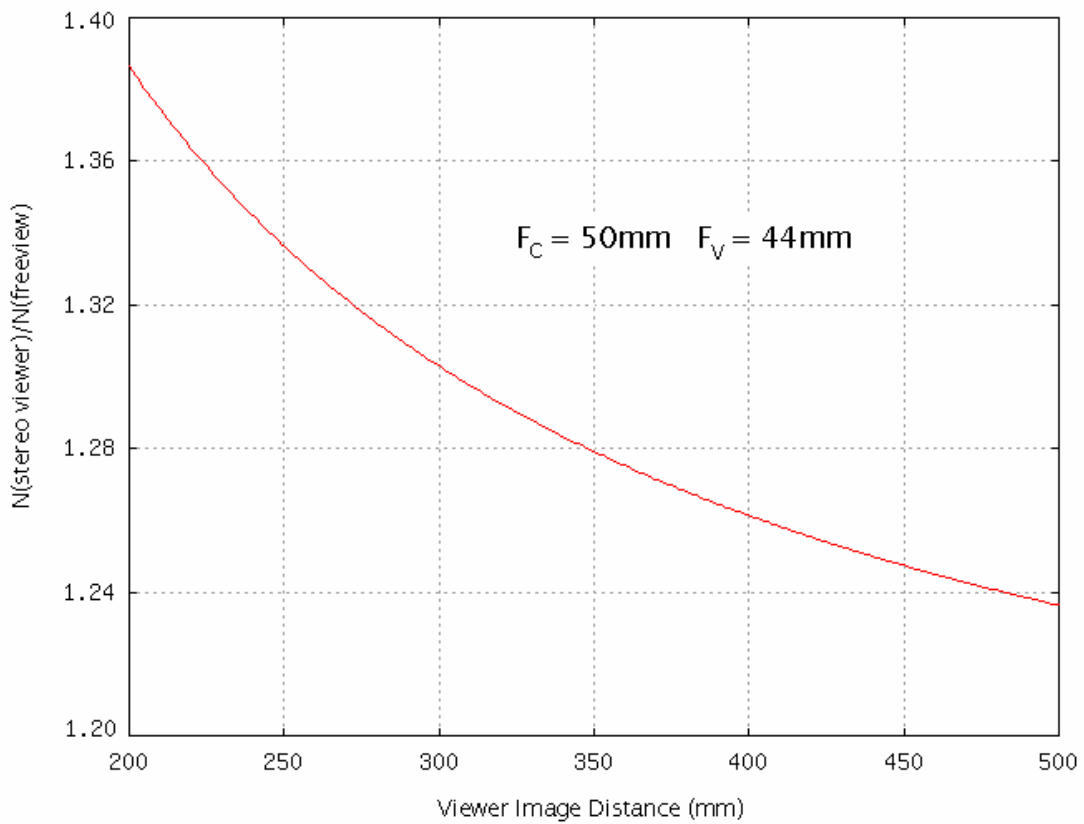
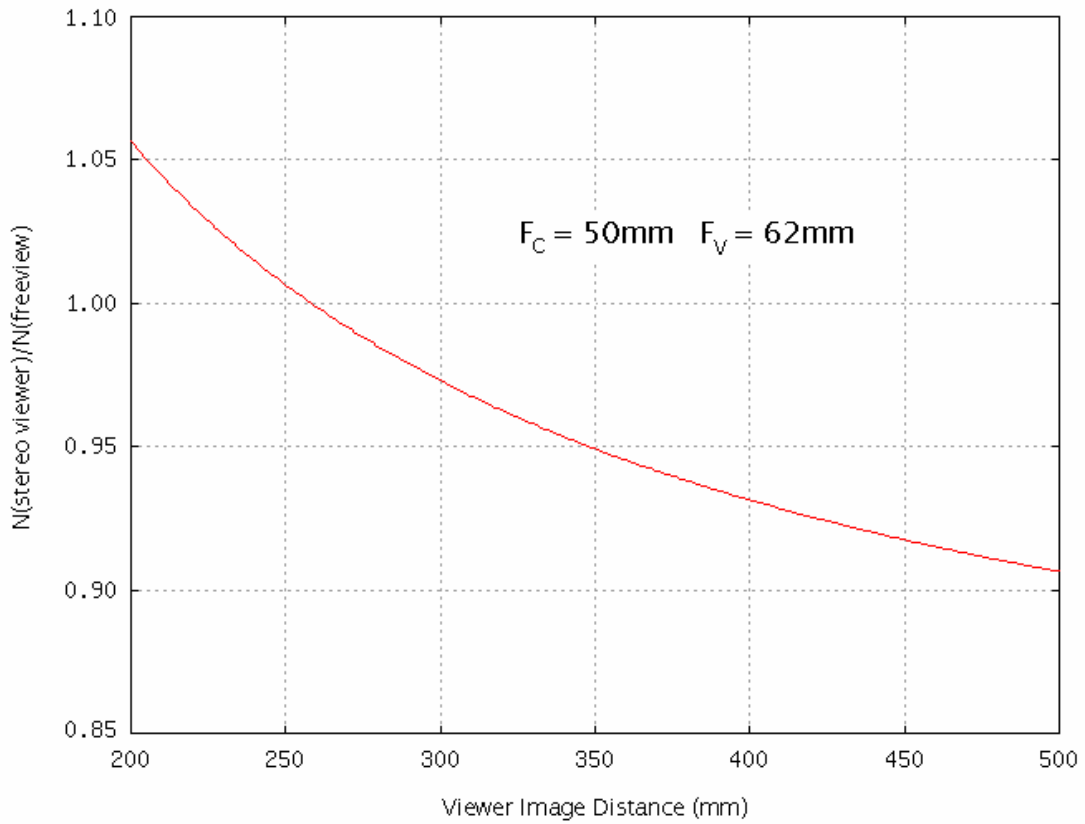

In cases such as these, the only recourse is to either generate two depth of field scales, one for the stereo viewer and one for freeviewing, or to use a viewer with a more appropriate focal length.

Insofar as the latter is concerned, this appropriate viewer lens focal length can be readily calculated. Since

$$\frac{N_V}{N_F} = F_C \left(\frac{F_V + D_I}{F_V D_I} \right)$$

then whenever the f/number relating to a stereo viewer N_V is equal to that for freeviewing N_F , the stereo bases will be identical for both. Thus **the same stereo base can be used for both freeviewing and a stereo viewer whenever the following condition holds**

$$\frac{1}{F_V} = \frac{1}{F_C} - \frac{1}{D_I}$$

Accordingly **the focal length of the viewer must always be greater than the focal length of the camera** for this to happen.

Some commonly used camera focal lengths in stereography are 35mm, 50mm and 80mm, the latter being typical of medium format cameras. The viewer focal lengths appropriate for these camera focal lengths are tabulated below and plotted on the next two pages.

Table of viewer focal lengths which ensure identical stereo base for both freeviewing and using a stereo viewer.

D_I (mm)	$F_C = 35\text{mm}$	$F_C = 50\text{mm}$	$F_C = 80\text{mm}$
	F_V (mm)	F_V (mm)	F_V (mm)
250	40.7	62.5	117.6
300	39.6	60.0	109.1
350	38.9	58.3	103.7
400	38.4	57.1	100.0
450	38.0	56.3	97.3
500	37.6	55.6	95.2

As indicated in the tabulated results, the same stereo base for both freeviewing and a stereo viewer can be secured for a 35mm focal length camera if one uses a viewer with a focal length of about 40mm. Similarly, when using a 50mm camera, the viewer should have a focal length of approximately 62mm and for the 80mm camera, the viewer should have a focal length of about 115mm. In all these cases the image distances lies between the range of 250mm and 300mm.

Conversely if a final image distance of say 450mm is preferred, then the appropriate viewer lens focal lengths should be about 38mm, 56mm and 97mm respectively.

It should be noted that the stereo viewer focal lengths need only be approximately equal to those quoted. An exact match is not necessary since the amount of perceived stereo depth in a freeviewed image can be changed by simply increasing or decreasing the viewing distance.

Viewer focal length versus viewer image distance (for 35mm and 50mm focal length lenses) that ensure the same stereo base for both freeviewing and when using a stereo viewer.

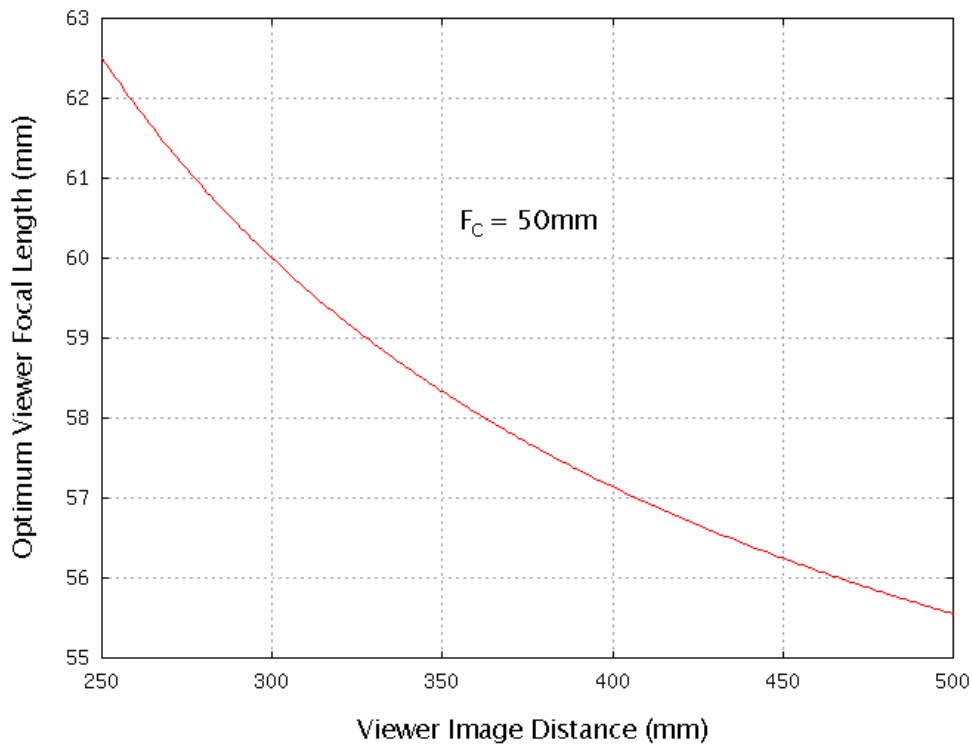
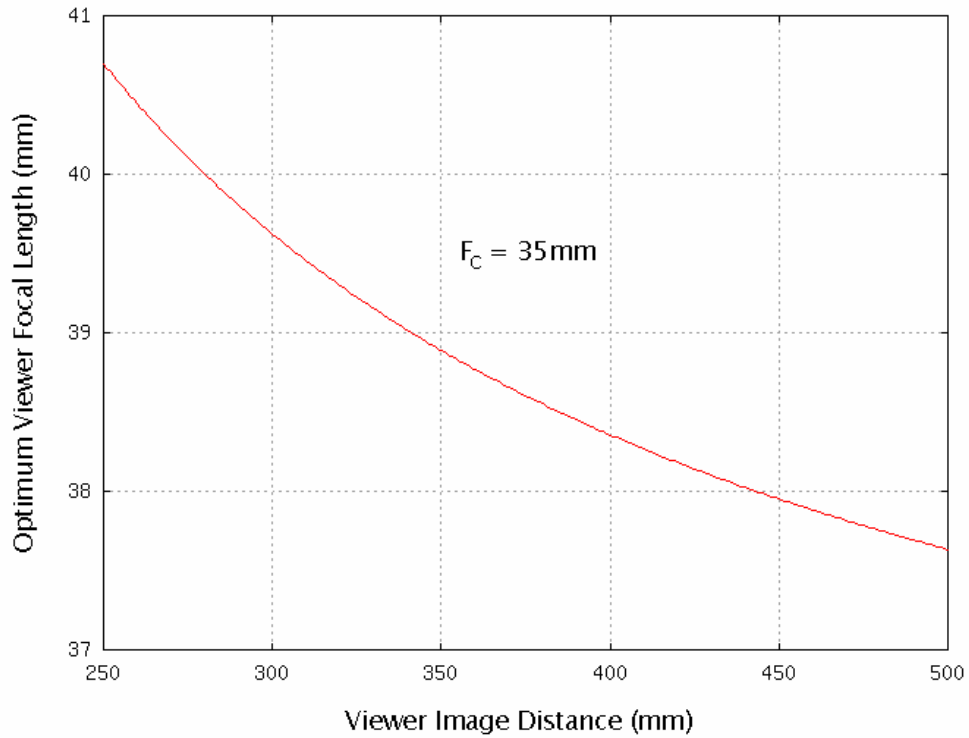

***Viewer focal length versus viewer image distance
(for an 80mm focal length lens)
that ensures the same stereo base for both
freeviewing and when using a stereo viewer.***

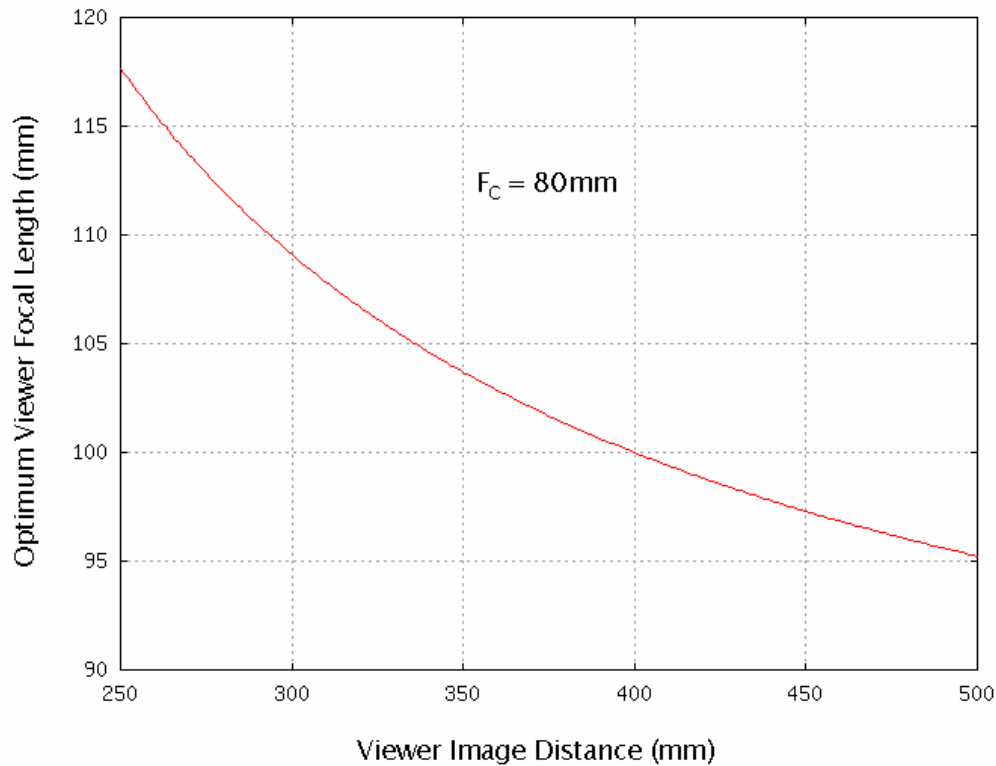

Tables of B versus N, their associated depth of field scales and graphs of B versus N for camera focal lengths of 35mm and 80mm respectively are presented in the following pages. The case of a 50mm lens was presented earlier. The viewer focal lengths are indicated as being approximate because the actual viewer focal length need not be exactly that quoted value.

A table of f/numbers and corresponding stereo bases for $F_C = 35\text{mm}$ and $F_C = 80\text{mm}$.

f/number N	B (mm)	B (mm)
	$F_C = 35\text{mm}$	$F_C = 80\text{mm}$
22	53.0	121.2
19.6	59.5	136.1
16	72.9	166.7
13.5	86.4	197.5
11	106.1	242.4
9.8	119.0	272.1
8	145.8	333.3
6.9	169.1	386.5
5.6	208.3	476.2

$F_c = 35\text{mm}$, $C = 0.0175\text{mm}$, $F_v \sim 40\text{mm}$ and $D_i \sim 254\text{mm}$

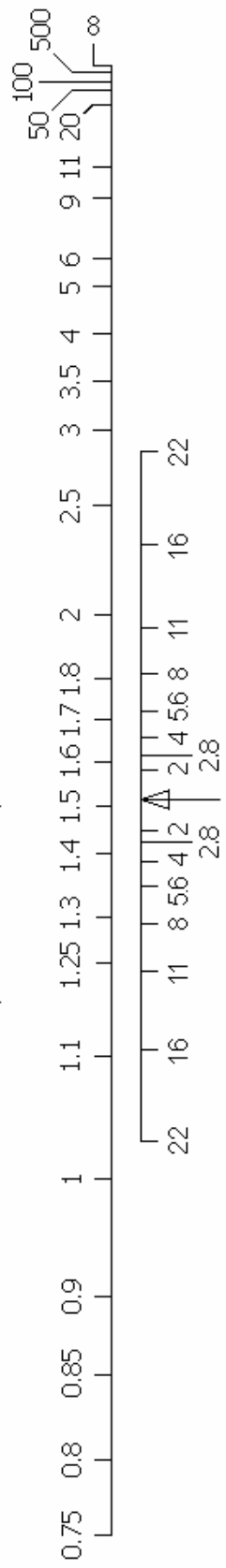

$F_c = 35\text{mm}$, $C = 0.0175\text{mm}$, $F_v \sim 40\text{mm}$ and $D_i \sim 254\text{mm}$

$F_c = 80\text{mm}$, $C = 0.04\text{mm}$, $F_v \sim 115\text{mm}$ and $D_i \sim 254\text{mm}$

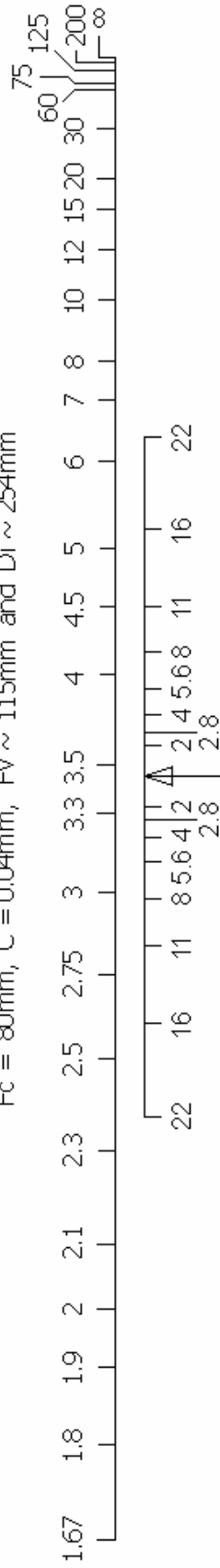

$F_c = 80\text{mm}$, $C = 0.04\text{mm}$, $F_v \sim 115\text{mm}$ and $D_i \sim 254\text{mm}$

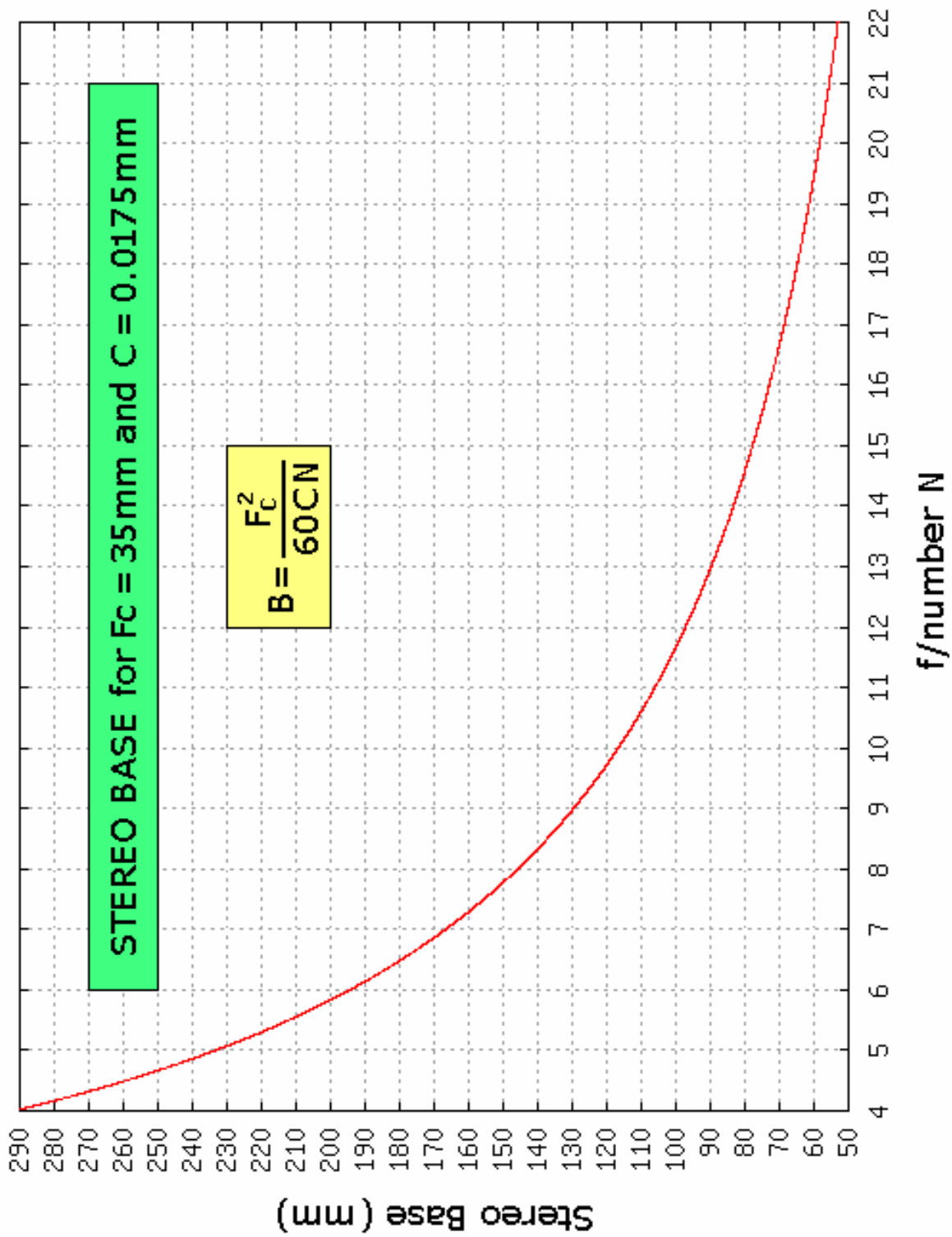

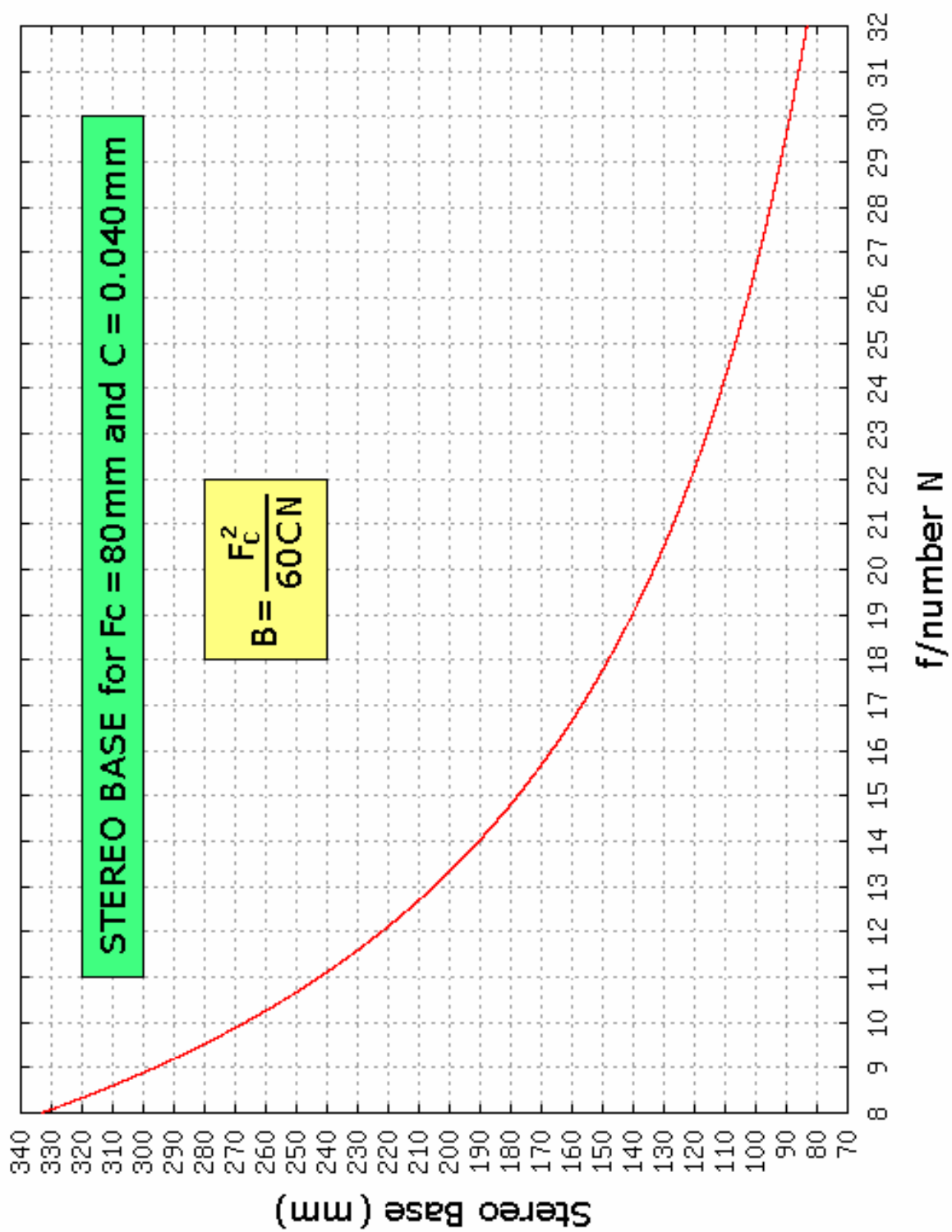

Summary of the Various Forms of the Di Marzio Equation

List of Variables

D_N = near point distance	D_F = far point distance
D_H = hyperfocal distance	S_O = object distance
N = f/number	C = circle of confusion diameter
F_C = camera lens focal length	F_V = viewer lens focal length
M = lens magnification	B = stereo base length
D_I = distance of the final image behind the stereo viewer lenses	

GENERAL STEREOGRAPHY

When Freeviewing or using a Stereo Viewer:

$$B = \frac{D_H}{60} = \frac{F_C^2}{60CN}$$

For freeviewing with $C = F_C/2000$, or when using a stereo viewer with

$$C = \frac{D_I F_V}{2000(F_V + D_I)}$$

the stereo base in both cases is given by

$$B = \frac{100F_C}{3N}$$

NEARBY SHALLOW OBJECTS (Macro Stereography)

Freeviewing:

$$B = \frac{D_N}{15}$$

$$B = \frac{F_C}{15} \left(1 + \frac{1}{M} \right)$$

Stereo Viewer:

$$B = K \left(\frac{D_N - 0.75 F_C}{15} \right)$$

$$B = K \left(\frac{F_C}{15 M} \right)$$

where K is a constant which depends on the characteristics of the stereo viewer and the intended placement of the final image. This constant only needs to be evaluated once. Its value can be found from

$$K = \frac{F_V}{F_C} \left(\frac{D_I}{F_V + D_I} \right)$$

DEEP DISTANT SCENES

Freeviewing:

$$B = \left(\frac{m}{m-1} \right) \frac{D_N}{30}$$

where $D_F = mD_N$ with $m \geq 2$ and where $S_O - F_C \approx S_O$.

Stereo Viewer:

$$B = K \left(\frac{m}{m-1} \right) \frac{D_N}{30}$$

where K is the same constant as before.

APPENDIX I

Extending the Range of Fixed Base Stereo Cameras

The main problem with stereo cameras is that they possess a fixed distance between the two taking lenses. Generally this fixed distance is between 65mm and 70mm, comparable to the interocular spacing. As a result of this fixed stereo base, realistic three dimensional images are usually produced when the near point distance is about 2m and the far point distance is much greater than this.

Since the base is fixed in stereo cameras, one might be under the impression that such cameras limit the user to subjects which include infinity (or thereabouts) as a far point. However, it is interesting to consider whether there are other subjects and depths of field where such a fixed stereo base would also be appropriate.

To this end, it is possible to rearrange the Di Marzio equation to get the f/number N in terms of the other variables, namely

$$N = \frac{F_C^2}{60CB}$$

For example, for a stereo camera with a lens focal length of 35mm, a lens separation of 65mm and a circle of confusion diameter of 0.0175mm, the above expression yields $N = 18$.

In other words, **for this stereo camera, ANY scene whose near and far points are at the limits of an f/18 depth of field can be recorded well stereographically, not just those scenes which involve infinity as a far point.**

The stereo camera in this example had a depth of field scale presented earlier. Using this scale it can be seen that this fixed base stereo camera can be used successfully not only for $(D_N, D_F) = (2m, \infty)$, but also for a range of other near and far points distances as well. Some of these distances include $(D_N, D_F) = (1.8m, 20m)$, $(D_N, D_F) = (1.6m, 9m)$, $(D_N, D_F) = (1.4m, 5m)$ and $(D_N, D_F) = (1m, 2m)$. Note that in all cases, the condition $D_N \geq 2D_F$ needs to be satisfied.

This is a very important point for fixed base stereo cameras. **The number of subjects that can be imaged is greatly increased because there is no longer an obligation to include infinity as a far point.**

Indeed, there are even more applications of fixed stereo base cameras. Such cameras can also be used quite successfully in the stereography of isolated, nearby shallow objects where the far to near distance ratio is less than two. In this case, the Di Marzio equation is

$$B = \frac{D_N}{15}$$

Hence **a fixed stereo base of 65mm can provide realistic stereoscopic depth for shallow subjects as long as the near point is 0.975m, that is, about 1m away.** A similar near distance is also predicted if a stereo viewer is used.

APPENDIX II

Comments Concerning the Diameter of the Circle of Confusion

The diameter of the circle of confusion for stereography depends on whether the final images are to be freeviewed or viewed through a stereo viewer and, for more conventional 2D photography, it depends on how big the final image will be and the expected viewing distance.

Freeviewing Enlarged Stereographic Images

The smallest distance Δ two points can be separated and still be resolved at a viewing distance D_v is

$$\Delta = \theta D_v$$

where θ is the angular resolution of the human eye.

If the negatives/slides are enlarged by a factor E , the diameter of the circle of confusion C is given by

$$C = \frac{\Delta}{E}$$

Moreover, the proper freeviewing distance is simply

$$D_v = ES_i \approx EF_c$$

Since the human eye has a resolution angle of $\theta \approx 0.028^\circ$ (approximately 1.7 arcminutes or 5×10^{-4} radians) then

$$\Delta = \frac{D_V}{2000}$$

and therefore the general expression for the diameter of the circle of confusion for freeviewing can also be expressed as

$$C = \frac{S_i}{2000} \approx \frac{F_c}{2000}$$

Note that this is the circle of confusion associated with acquiring acceptably sharp images and has nothing to do stereoscopic depth.

Viewing using the Stereoscopic Viewer

The images on the film chips placed in a stereo viewer undergo a linear magnification M_L given by the expression

$$M_L = \frac{F_V + D_I}{F_V}$$

The smallest distance Δ two points can be separated and still be resolved at an image viewing distance D_I is

$$\Delta = \theta D_I$$

and, in this case,

$$C = \frac{\Delta}{M_L}$$

and so the diameter of the circle of confusion appropriate for a stereo viewer is given by

$$C = \frac{D_I F_V}{2000 (F_V + D_I)}$$

Some examples for the diameter of the circle of confusion C resulting from various combinations of viewer image distances D_I and viewer lens focal lengths F_V are presented in the following tables and graphs.

These plots reveal that **the diameter of the circle of confusion**

- **increases slowly with increasing viewer image distance.** If the final image is placed further and further away, it will appear smaller and smaller, thus allowing the diameter of the circle of confusion to increase.
- **increases significantly with increasing viewer focal length.** This is due to the fact that although F_V appears in both the numerator and denominator, the larger value of D_I in the denominator allows C to increase faster with increasing F_V than with increasing D_I .

$F_v = 40\text{mm}$ D_I (mm)	C (mm)
200	0.0167
250	0.0172
300	0.0176
350	0.0179
400	0.0182
450	0.0184
500	0.0185

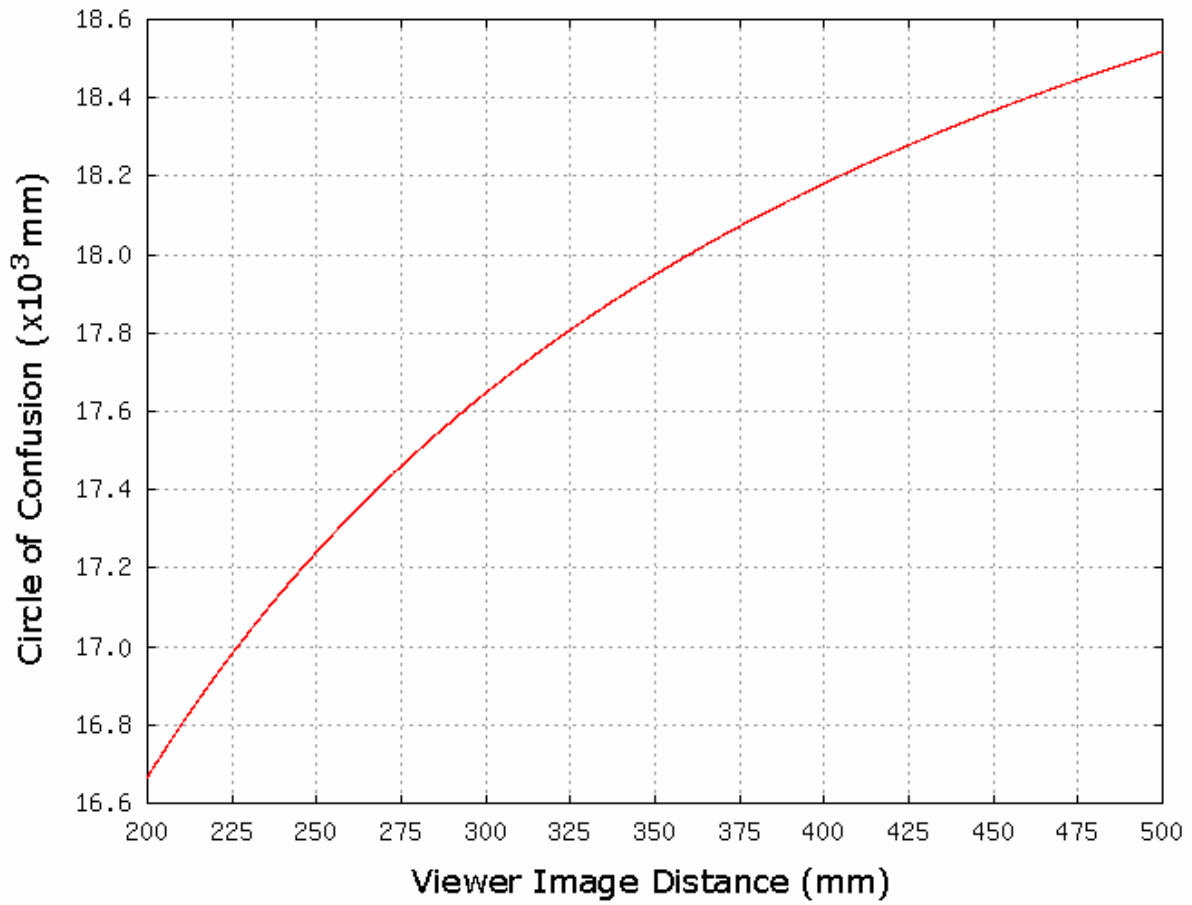

$D_I = 300\text{mm}$ F_V (mm)	C (mm)
40	0.0176
45	0.0196
50	0.0214
55	0.0232
60	0.0250
65	0.0267
70	0.0284
75	0.0300
80	0.0316

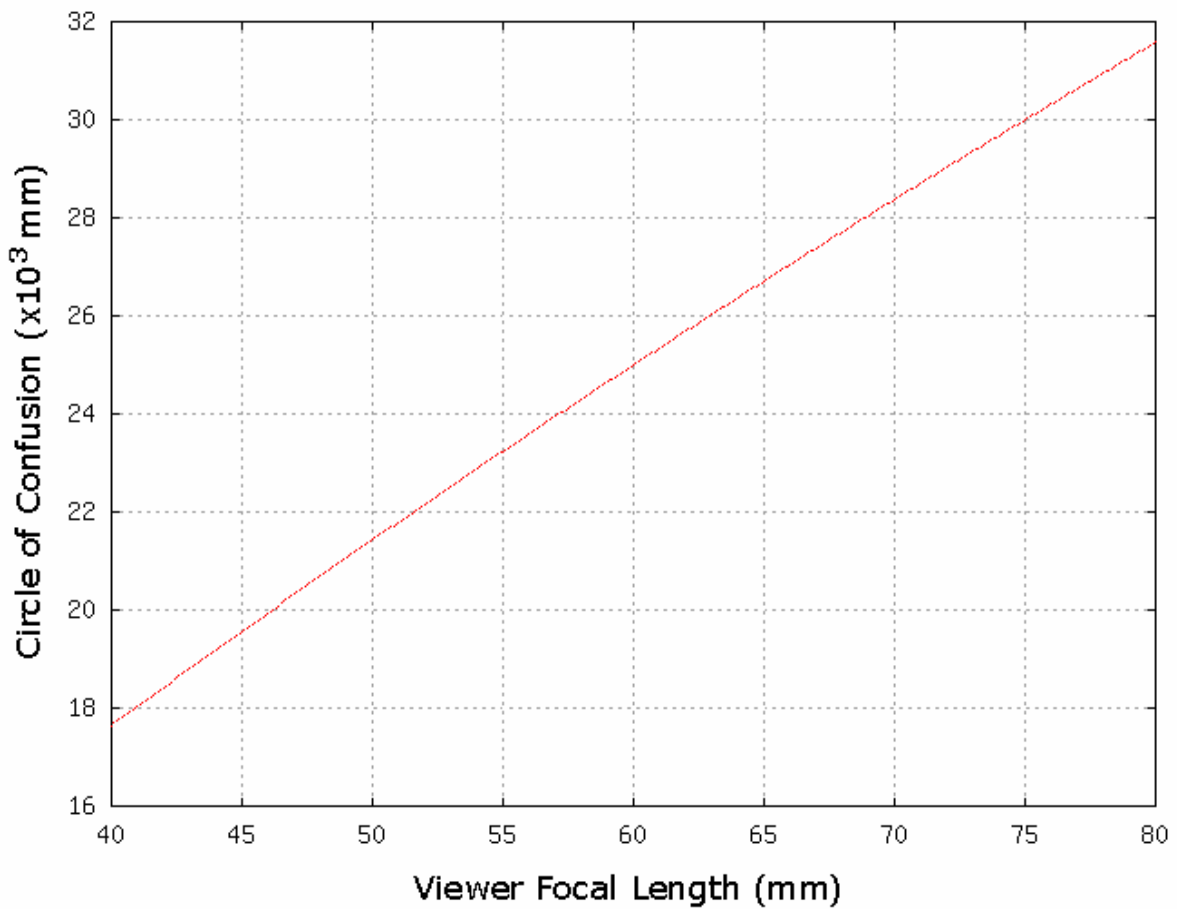

General 2D Photography

Optical diffraction limits the smallest separation Δ_{fc} of two points of light (produced by a circular hole of aperture D) at the film/chip plane that are just barely resolved to

$$\Delta_{fc} = \frac{1.22\lambda F_c}{D} = 1.22\lambda N$$

where λ is the wavelength of light and N is the usual f/number. Using an average wavelength of (yellow-green) light as 550×10^{-6} mm yields

$$\Delta_{fc}(\text{mm}) = \frac{N}{1490}$$

Depending on the value of N , this can be larger than the resolution of the film or chip. Insofar as enlargements are concerned, the larger of Δ_{fc} or the resolution of the film/chip needs to be used.

For example, if a digital chip has a pixel size of 0.01mm and one intends to use f/22, then $\Delta_{fc} = 22/1490 = 0.015\text{mm}$. In this case the larger of the two separations is due to diffraction, and therefore Δ_{fc} should be set to 0.015mm.

Conversely, if f/11 were being used, then $\Delta_{fc} = 11/1490 = 0.007\text{mm}$. The larger of the two separations this time is the pixel size and so, here, Δ_{fc} should be set to 0.01mm. Naturally these equations are based on "ideal" optics.

After an enlargement by a factor E , the smallest resolvable detail are now separated by a distance $E\Delta_{fc}$ and this needs to be smaller than the human eye can see at the chosen viewing distance D_v .

The angular resolution of a "sharp" human eye is about $1/2000$ of a radian. At a viewing distance D_v this corresponds to resolving points only $D_v/2000$ mm apart. Therefore, in order for an enlarged image to appear sharp,

$$E\Delta_{fc} \leq \frac{D_v}{2000}$$

In other words, the enlargement needs to satisfy the condition

$$E \leq \frac{D_v}{2000\Delta_{fc}}$$

Using the previous example with $f/22$, Δ_{fc} is 0.015mm and with an intended viewing distance of 400mm , the maximum enlargement factor for the original image is $E = 13X$.

APPENDIX III

Correction for Arbitrary Freeviewing Distances

If one allows freeviewing distance to be arbitrary, then the stereo base needs to be adjusted to accommodate for intended viewing distance. The best freeviewing distance D_B that ensures the same viewing angle as that produced by the camera lens is given by $D_B = ES_i$ where E is the enlargement factor for the original image and S_i is the lens to film distance. For non-macro stereography $S_i \approx F_C$.

For freeviewing distances significantly greater than D_B , the image will appear to have too much depth, and vice versa. However there are alternatives to modifying the stereo base, namely

1. The image can be further enlarged so that D_B coincides with the intended cross-eyed freeviewing distance. This may present a problem sometimes if the original image is of poor quality.
2. Problems with depth can occur if freeviewing images captured with very short focal length lenses, as in some digital cameras. A simple solution would be to use longer focal length lenses in a conventional camera or a digital SLR. Generally however, even short focal length lenses can produce sufficiently good image quality capable of handling enough enlargement to allow freeviewing from any reasonable distance.

If these are not feasible options, then modifying the stereo base to produce an image with realistic depth and distance is possible. This is represented diagrammatically below.

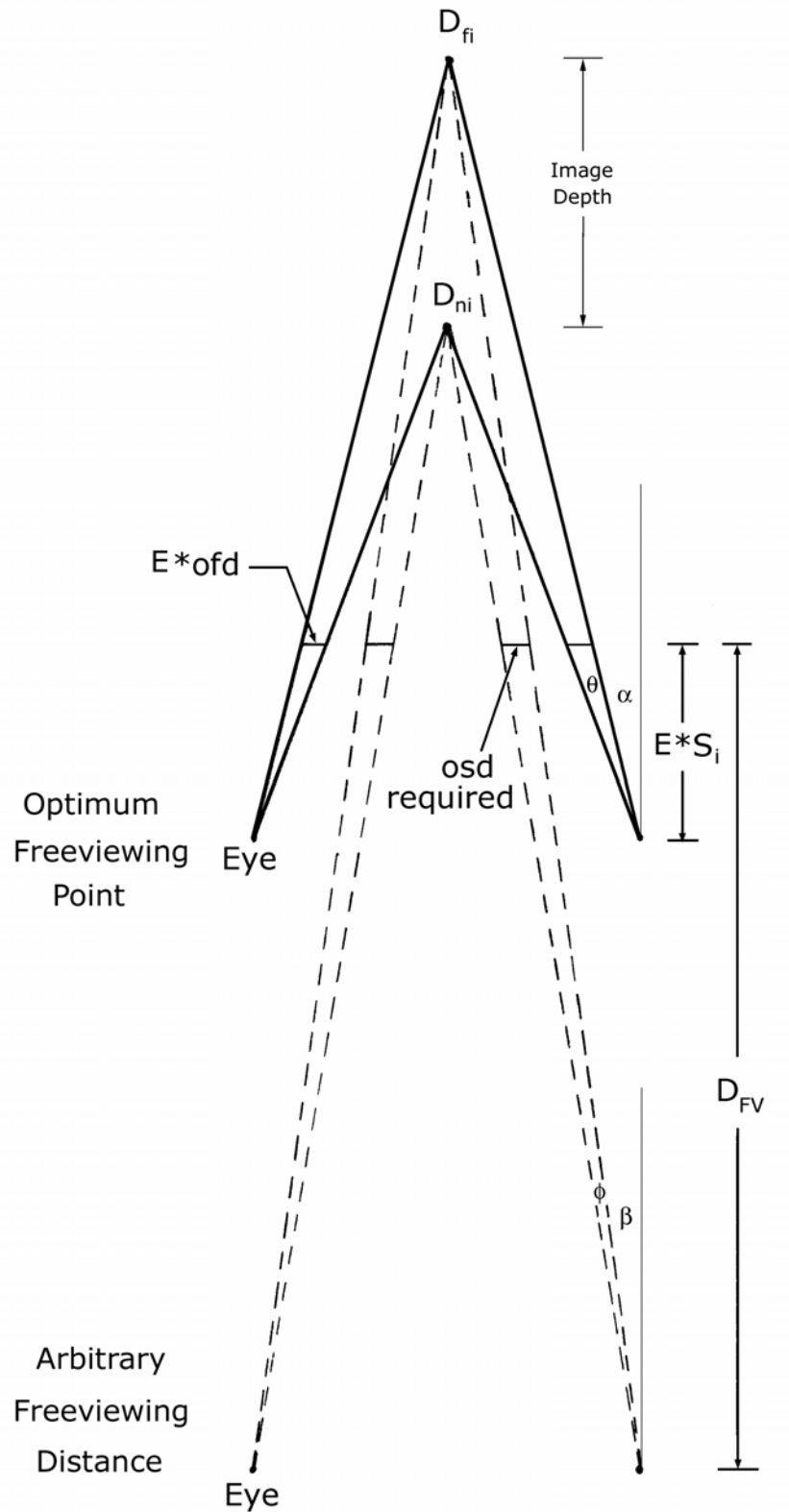

Diagram Legend:

D_{FV}	=	arbitrary freeviewing distance
ES_i	=	optimum freeviewing distance
S_i	=	image distance within the camera (lens to film/chip plane)
E	=	enlargement factor of original image
$E*ofd$	=	on screen deviation
ofd	=	on film deviation
D_{ni}	=	image near point distance behind stereo pair along z axis
D_{fi}	=	image far point distance behind stereo pair along z axis
θ	=	parallax angle at the optimum freeviewing distance
Φ	=	parallax angle at the arbitrary freeviewing distance
α	=	convergence angle of D_{fi} at optimum freeviewing distance
β	=	convergence angle of D_{fi} at arbitrary freeviewing distance

As is evident from the previous diagram, one needs to find the on screen deviation (osd) which will place an image, when viewed from an arbitrary distance, at the same place and with the same depth as when viewed from the optimum freeviewing distance. It would be possible to place this image with the same depth closer, but this would entail increasing the convergence angle β and requiring more aggressive cropping. Accordingly it is best to adhere to the geometry displayed in the diagram.

The angular quantities α , β , θ and Φ are all small. Their size has been exaggerated in the diagram for illustrative purposes only. The units for these angles are radians.

The parallax angle θ is

$$\theta = \frac{ofd}{S_i}$$

The convergence angle α is a variable which depends on how you set up your stereo pair for parallel viewing. It can be written as

$$\tan \alpha = \frac{\text{ipd}}{2(D_{fi} + ES_i)} \approx \alpha$$

Similarly

$$\tan(\alpha + \theta) = \frac{\text{ipd}}{2(D_{ni} + ES_i)} \approx \alpha + \theta$$

These two expressions enable the near and far point image distances to be determined. Subtracting the previous equations yields

$$\tan(\alpha + \theta) - \tan(\alpha) \approx \theta = \frac{\text{ipd}}{2} \left[\frac{1}{D_{ni} + ES_i} - \frac{1}{D_{fi} + ES_i} \right]$$

Since

$$\theta = \frac{\text{ofd}}{S_i} \quad \text{and} \quad \frac{1}{D_{fi} + ES_i} = \frac{2\alpha}{\text{ipd}}$$

then the near image distance can be found from

$$D_{ni} = \frac{(\text{ipd}) S_i}{2(\text{ofd} + \alpha S_i)} - ES_i$$

and the far image distance is

$$D_{fi} = \frac{\text{ipd}}{2\alpha} - ES_i$$

These expressions for near and far image distances are necessary for the evaluation of stereo base correction for freeviewing at arbitrary distances. In order to find this correction, the parallax angle Φ needs to be determined.

$$\tan \beta = \frac{\text{ipd}}{2(D_{fi} + D_{FV})} \approx \beta$$

$$\tan(\beta + \phi) = \frac{\text{ipd}}{2(D_{ni} + D_{FV})} \approx \beta + \phi$$

Subtracting these two equations as earlier gives

$$\tan(\beta + \phi) - \tan(\beta) \approx \phi = \frac{\text{ipd}}{2} \left[\frac{1}{D_{ni} + D_{FV}} - \frac{1}{D_{fi} + D_{FV}} \right]$$

$$\therefore \phi = \frac{\text{ipd}}{2} \left\{ \frac{D_{fi} - D_{ni}}{(D_{ni} + D_{FV})(D_{fi} + D_{FV})} \right\}$$

The expression for parallax angle θ can then be written in a similar form, namely

$$\theta = \frac{\text{ipd}}{2} \left\{ \frac{D_{fi} - D_{ni}}{(D_{ni} + ES_i)(D_{fi} + ES_i)} \right\}$$

Therefore the ratio of these two parallax angles is

$$\frac{\phi}{\theta} = \left(\frac{D_{ni} + ES_i}{D_{ni} + D_{FV}} \right) \left(\frac{D_{fi} + ES_i}{D_{fi} + D_{FV}} \right)$$

The required on screen deviation osd is then

$$\text{osd} = \phi D_{FV}$$

Hence the correction factor CF for the on film deviation ofd and thus the stereo base B as well is simply

$$CF = \frac{\text{osd}}{E(\text{ofd})} = \frac{\phi D_{FV}}{E(\text{ofd})}$$

Using the expression for Φ/θ and the fact that $\theta = \text{ofd} / S_i$, yields

$$CF = \left(\frac{D_{FV}}{ES_i} \right) \left(\frac{D_{ni} + ES_i}{D_{ni} + D_{FV}} \right) \left(\frac{D_{fi} + ES_i}{D_{fi} + D_{FV}} \right)$$

NOTE:

- If $D_{FV} = ES_i$, then $CF = 1$ as expected.
- If $D_{fi} \rightarrow \infty$, then the correction factor is

$$CF = \left(\frac{D_{FV}}{ES_i} \right) \left(\frac{D_{ni} + ES_i}{D_{ni} + D_{FV}} \right)$$

- It is NOT sufficient to simply change the value of the stereo base by applying this correction factor. One must ALSO change the separation of the stereo pair. This can be seen in the original diagram and is demonstrated in the following example.

Stereography with a short focal length digital camera

Sample data:

$$F_C = 7.5\text{mm}$$

$$E = 15.9 \text{ (portrait mode)}$$

$$\text{ipd} = 66\text{mm}$$

$$S_i = F_C \text{ (non macro case)}$$

$$D_{FV} = 500\text{mm}$$

$$ES_i = 119\text{mm} \text{ (optimum freeviewing distance)}$$

$$\text{on screen image width} = 63.5\text{mm}$$

$$\alpha = 1.2^\circ$$

$$B = 67\text{mm}$$

Using this data, one finds that $D_{ni} = 489.0\text{mm}$, $D_{fi} = 1456.6\text{mm}$ and the corresponding correction factor for stereo base is $CF = 2.08$. Hence **instead of using a stereo base of 67mm, a base of 139mm should be employed in this situation.**

In addition, the difference between the values of $\alpha = 1.2^\circ$ at a distance of $ES_i = 119\text{mm}$ and $\beta = 0.966^\circ$ at a distance of 500mm implies that **each of the stereo pair needs to be moved closer together by 5.9mm.** Some cropping along the vertical would be necessary.

APPENDIX IV

“Stellar” Stereography

There is one specific situation where the “1 in 30” rule is always valid. This occurs when the far point distance is infinity, and there is no better infinity than the stars. Such “stellar” stereography would thus involve the imaging of a tree or building (or any other object) in front of these stars. The three dimensionality would then arise from the parallax of the nearby object(s) relative to the distant stars.

Naturally, as stars are very faint objects, exposure times will be of the order of at least several seconds. However stars move across the sky because of the rotational motion of the Earth. Accordingly, one needs to determine the maximum exposure time that will lead to the formation of star trails that are too small to be detected on the final print or when viewed through a stereo viewer.

This maximum exposure time depends on the declination δ of the star(s), the focal length F_C of the camera and the amount of enlargement E to be employed in producing the final image.

The equatorial angular velocity ω_e of stars (attributable to the rotation of the Earth) is constant, namely

$$\omega_e = \frac{2\pi}{86400} = 7.2722 \times 10^{-5} \text{ rad s}^{-1}$$

and so the angular velocity ω at any stellar declination δ is simply

$$\omega = \omega_e \cos \delta$$

The celestial angle θ (in radians) traversed in a time t is then

$$\theta = \omega t$$

and the length L of the stellar trail on the film is

$$L = F_c \theta = F_c \omega t$$

Since the human eye has a resolution θ_E of about 5×10^{-4} radians, then the smallest distance (stellar trail) that can be discerned at a viewing distance D_V , and after an enlargement by a factor E is applied to the original image, is given by

$$L = \frac{D_V \theta_E}{E}$$

Since this distance L corresponds to the stellar trail length, then

$$L = \frac{D_V \theta_E}{E} = F_c \omega_e \cos \delta t$$

Therefore the time taken to reach a barely discernible stellar trail is

$$t = \frac{D_V \theta_E}{E F_c \omega_e \cos \delta} = \frac{6.875 D_V}{E F_c \cos \delta}$$

A list of maximum exposure times (in seconds) for a 4X enlargement of the original image and with a viewing distance of 350mm is presented in the following table for various focal length camera lenses and stellar declinations.

Note that the best way to handle this type of stereography would be to employ two identical cameras separated by $D_N/30$. This would allow a maximum exposure time for both images. Composition is important and is best achieved during daylight hours. It makes distance measurements much easier as well.

In order to increase the number of stars recorded, the exposure times can be increased by pointing both cameras closer to the celestial pole. In the southern hemisphere, the South Celestial Pole is due South and elevated by an angle equal to the latitude of the observer. Particularly good images can be acquired by "painting" nearby trees (and similar nearby objects) with a high wattage floodlight during the exposure.

Depending on lens quality and atmospheric conditions, stars may be sufficiently bloated as to permit exposure times as much as 2X the listed values. If one is prepared to tolerate some slight star trailing, then exposures 4X the tabulated values are possible. A good compromise for most standard lenses is 3X. However sharp, high quality lenses require adherence to the listed exposure times.

Maximum exposure times that prevent the detection of star trails at a viewing distance of 350mm after a 4X enlargement has been applied.

E = 4	F_c = 35mm	F_c = 50mm	F_c = 80mm
δ↓	‡ Maximum Exposure Time (sec)		
0	17.2	12.0	7.5
5	17.3	12.1	7.5
10	17.5	12.2	7.6
15	17.8	12.5	7.8
20	18.3	12.8	8.0
25	19.0	13.3	8.3
30	19.8	12.9	8.7
35	21.0	14.7	9.2
40	22.4	15.7	9.8
45	24.3	17.0	10.6
50	26.7	18.7	11.7
55	30.0	21.0	13.1
60	34.4	24.1	15.0
65	40.7	28.5	17.8
70	50.3	35.2	22.0
75	66.4	46.5	29.1
80	99.0	69.3	43.3
85	197.2	138.1	86.3

‡ For average lenses, the maximum times can be up to 3X these values.